

ENFRIADOR ECOLÓGICO

# EVER

 SISTEMA EVAPORATIVO AUTÓNOMO

Referencia: 1003651573

Gama Caravanning

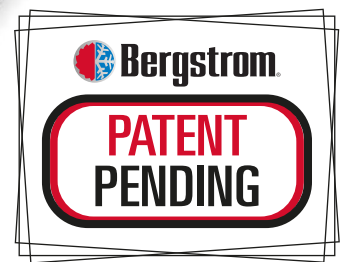
INSTRUCCIONES DE MONTAJE **ES**MOUNTING INSTRUCTIONS **EN**INSTRUCTIONS DE MONTAGE **FR**MONTAGEANWEISUNGEN **GE**ISTRUZIONI DI MONTAGGIO **IT**

Gracias por su adquisición y por confiar en nuestra gama de productos Caravaning. **EVER** es un enfriador ecológico de techo de altas prestaciones diseñado y fabricado por **Bergstrom** para ser utilizado en autocaravanas y otros vehículos de recreo a motor parado o en marcha. **EVER** es la opción más apropiada para mantener seguras y frescas a las mascotas.

**EVER** está diseñado con la más avanzada tecnología para lograr un eficaz rendimiento, una reducción en el gasto de combustible y en las emisiones de CO<sub>2</sub> a la atmósfera. Son estas características lo que lo hace único en el mercado de la refrigeración de los vehículos de recreo.



**Lea atentamente este documento antes de instalar el producto.** Conserve este documento para futuras consultas. La documentación original ha sido escrita en español, por lo que el resto de idiomas son traducciones.

Tiene a su disposición todos los manuales del producto en sus versiones digitales (PDF) en <https://www.bergstromspain.com/>

Cualquier operación de venta o de garantía está sometida a nuestras condiciones generales de venta en su versión más actualizada, publicada en nuestra página web <https://www.bergstromspain.com/>

Este manual refleja los últimos avances técnicos de esta gama en el momento de la publicación. No obstante, pueden existir diferencias debidas al perfeccionamiento continuo.

### Explicación de símbolos



- **Advertencia:** Aviso de seguridad que informa sobre una situación, que de no evitarse, puede provocar lesiones graves o la muerte.



- **Peligro:** Riesgo de corte. Señala una situación que podría provocar un corte.



- **Peligro:** Riesgo de electrocución. Señala una situación que podría provocar una electrocución.



- **Aviso:** Aviso de seguridad que informa sobre una situación, que de no evitarse, puede provocar daños al equipo o a otros materiales.



- **Información:** Información adicional sobre la instalación o el manejo del producto.



- **Frágil:** Indica una situación en la que se debe operar con cuidado para no causar daños al equipo y a otros materiales.



### Explicación de responsabilidades

- **Dirna Bergstrom** declina toda responsabilidad ante los daños ocasionados en los siguientes casos:

- Daños en el producto debido a influencias mecánicas y sobretensiones.
- Modificaciones realizadas en el equipo sin el consentimiento expreso del fabricante.
- Utilización del equipo para fines no descritos en este documento.
- Una inadecuada manipulación o instalación del enfriador.

- Al instalar **EVER** en el techo hay que tener en cuenta que, normalmente, los vehículos que vienen provistos de claraboya, tienen una estructura suficiente para soportar el peso de la unidad. Sin embargo, cuando esto no ocurre y es necesario realizar un corte en el techo, o incluso en el caso de llevar claraboya, el material no es lo suficientemente resistente (techos de fibra, plástico, etc.,) **el instalador debe decidir bajo su responsabilidad**, sobre la necesidad de reforzarlo para evitar una posible deformación, rotura, entrada de agua, etc., habilitando los medios necesarios para que esto no ocurra.

**EVER** es un enfriador versátil cuya instalación también puede realizarse girado 180° con el fin de adecuarlo al espacio disponible en el techo del vehículo y no interfiera con el resto de accesorios instalados.



### Advertencias durante el montaje

- La instalación, reparación y mantenimiento de este equipo, solo puede ser realizada por aquel personal técnico que posea una formación suficiente en aire acondicionado para vehículos, posibles peligros y normas aplicables.
- Leer detenidamente las instrucciones de montaje antes de iniciar la instalación del enfriador. Durante la instalación, seguir al pie de la letra las instrucciones indicadas.
- Desconectar la llave de contacto antes de iniciar la instalación del enfriador.
- Desconectar la batería del vehículo antes de iniciar la instalación del enfriador.

- Instale **EVER** de forma segura para evitar caídas.
- Utilizar las herramientas adecuadas para cada operación.
- Durante la instalación, asegurar la conexión de los componentes eléctricos, verificando su encaje correcto.
- Si durante la instalación los cableados atraviesan paredes con bordes afilados, utilice conductos o guías para evitar que los cables se dañen.



### Documentación relacionada

- Guía rápida: 1003653001
- Manual de usuario: 1003652994
- Listado de recambios: 1003652997
- Diagnóstico de averías: 1003652996

De conformidad con la normativa internacional de gestión de calidad ISO 9001, Calidad en Automoción IATF 16949 y Gestión Ambiental ISO 14001, **Dirna Bergstrom** utiliza procesos de aseguramiento de la excelencia para garantizar la máxima calidad de sus productos. Certificado por IQNet Quality System.



- **Aviso importante:** Tenga la precaución al conectar el enfriador de no invertir las polaridades. Si esto sucediera, la placa de mandos no se encenderá y el equipo no se pondrá en funcionamiento.
- Una vez instalado el enfriador, deberá entregarse al usuario las tapas de invierno y la guía rápida del producto.



### Herramientas recomendadas para el montaje

- Destornillador de estrella thorx 10.
- Destornillador plano.
- Llave fija de 10.
- Flexómetro.
- Sierra de calar.
- Cutter.



### Uso adecuado del producto

- **EVER** es un enfriador ecológico de techo de altas prestaciones apropiado para ser utilizado en caravanas y otros vehículos de recreo. No es adecuada su instalación y funcionamiento en maquinaria agrícola ni de construcción sujeta a intensas vibraciones.
- Para asegurar el correcto funcionamiento de la unidad, se recomienda mantener el vehículo en posición horizontal o, de no ser posible, situar la parte delantera del enfriador en la posición más elevada. Si la advertencia  llega a aparecer en pantalla, el modo AUTO o MANUAL volverá a activarse una vez el vehículo esté mejor nivelado.
- El uso no conforme al previsto anula la garantía del enfriador y excluye de responsabilidad al fabricante.
- Si no está seguro de cómo utilizar **EVER**, revise el manual de usuario del producto.

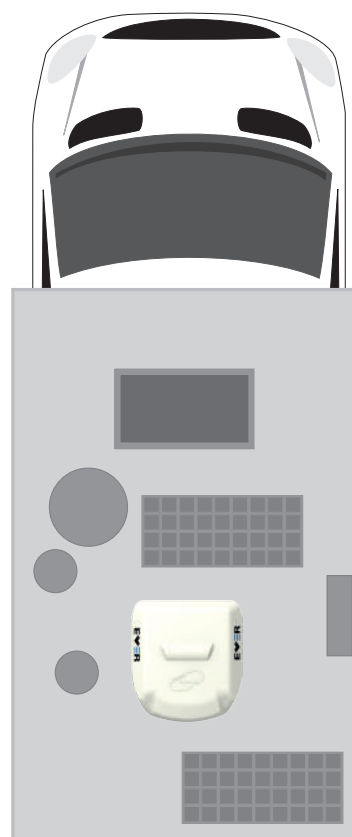
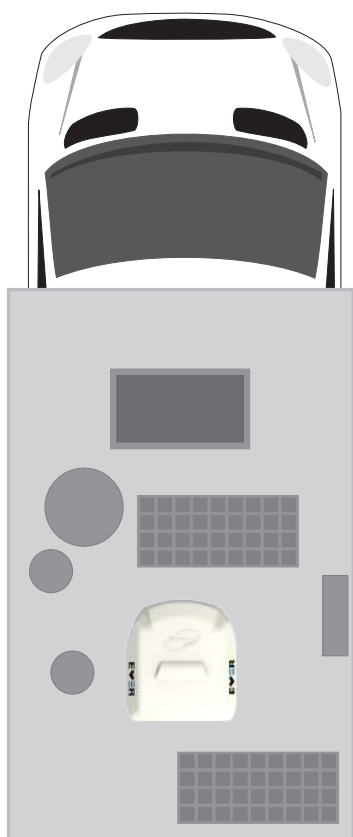
**OPCIONES DE MONTAJE**

**Atención:** Para garantizar una correcta ventilación del equipo y evitar un deficiente funcionamiento del mismo, debe mantenerse libre un espacio de al menos 10 cm alrededor de la unidad.

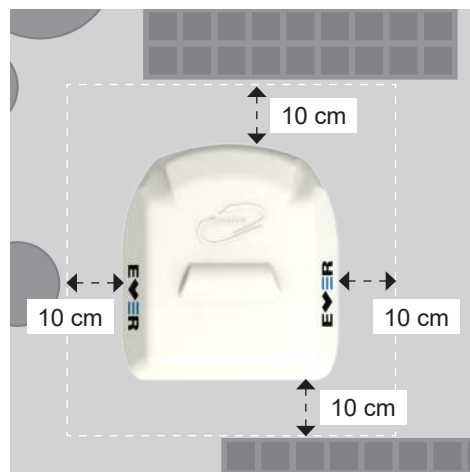

# OPERACIONES PREVIAS A LA INSTALACIÓN DEL ENFRIADOR EVER EN VEHÍCULOS QUE NO DISPONGAN DE ESCOTILLA EN EL TECHO

**1** Coger la plantilla de corte situada en la caja del equipo **EVER** y presentar en el techo del vehículo para marcar la posición correcta donde se instalará el enfriador.

**Atención:** Comprobar que la marca realizada en el exterior no interfiere con ningún elemento del interior del vehículo para el montaje de la consola interior del enfriador.

**Nota:** **EVER** es un enfriador versátil cuya instalación puede también realizarse girado 180° con el fin de adecuarlo al espacio disponible en el techo del vehículo y que no interfiera con el resto de accesorios instalados.

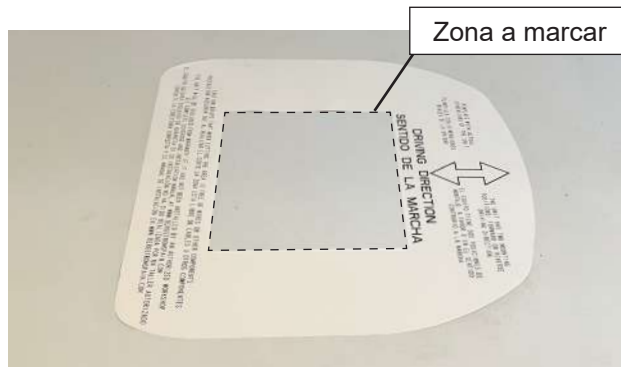

**2** Desde el exterior del vehículo, marcar el espacio de 400 x 400 mm donde se asentará el enfriador. Dar (1) taladro en cada una de las 4 esquinas del espacio marcado.

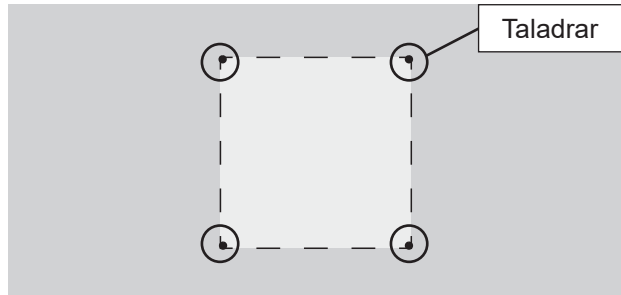

**3** Desde el exterior del vehículo unir los taladros cortando el techo con una sierra de calar. Completar el corte desde interior cortando la guata y el falso techo.

**Atención:** Tener precaución al realizar el corte ante la posibilidad de encontrarse con un paso de cables.





## REQUERIMIENTOS PARA LA INSTALACIÓN DEL ENFRIADOR EVER EN VEHÍCULOS CON ESCOTILLA DISPONIBLE EN EL TECHO



**Atención:** EVER solo puede instalarse en vehículos con escotilla que dispongan de:

- Huevo en el techo de 400 x 400 mm
- Espesor de techo desde 30 hasta 60 mm

**4**

Desmontar la escotilla y el marco del vehículo donde va a situarse el enfriador **EVER**.

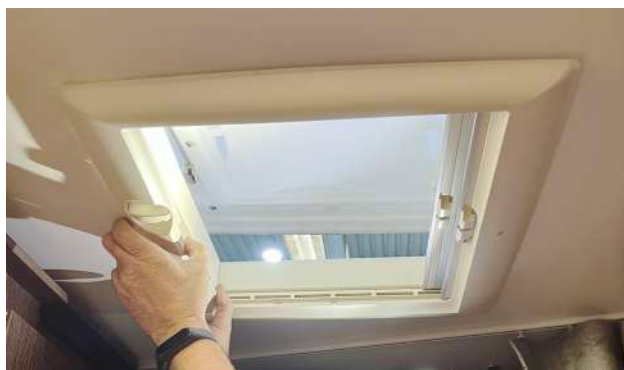

## PROCESO DE INSTALACIÓN DEL ENFRIADOR EVER

**5**

Colocar junta EPDM de montaje alrededor del hueco de la escotilla o del corte realizado.





**COMO CORTAR LA JUNTA EPDM PARA EVITAR FILTRACIONES DE AGUA EN EL INTERIOR DEL VEHÍCULO**

**A-** Pegar la junta EPDM manteniendo 100 mm de papel protector por cada lado.

**B-** Quitar las dos piezas de papel.

**C-** Pegar extremos de la junta EPDM.

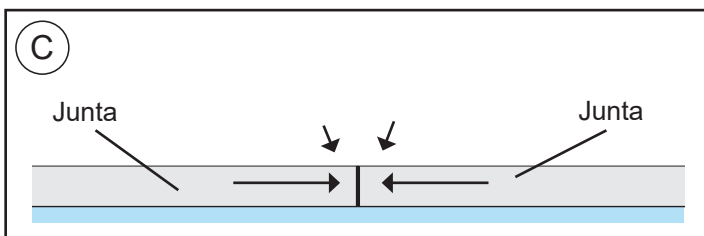
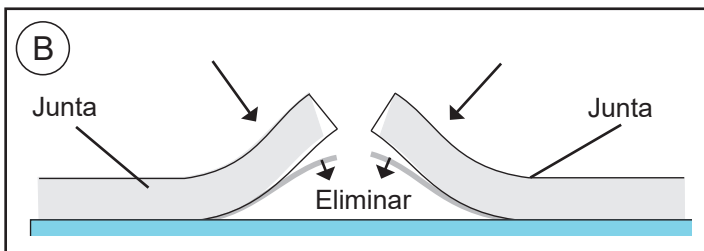
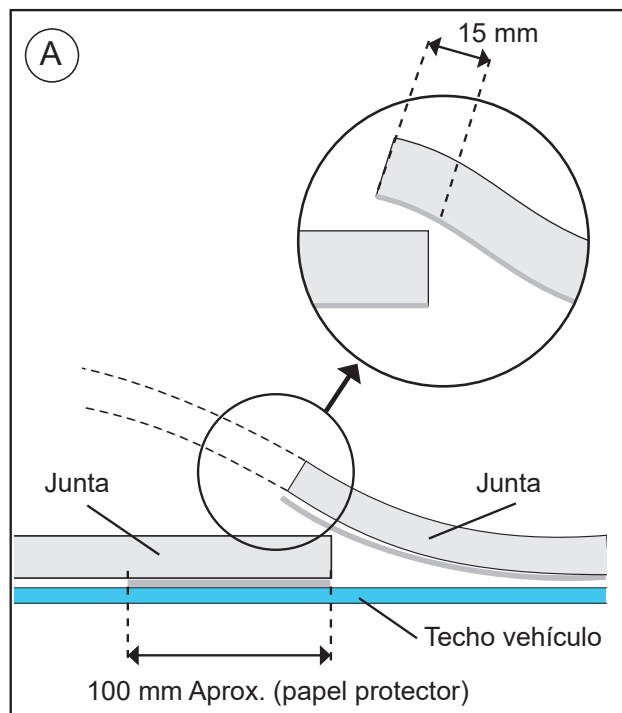

**6**

Posicionar el enfriador sobre la junta de montaje centrándolo al hueco del techo desde el interior del vehículo asegurando que los (4) puntos de fijación de los soportes de la base del enfriador queden centrados en el hueco del techo.



**7**

Montar (4) espárragos de 60 mm en los puntos de fijación de la base del enfriador.



**8**

Fijar los (4) espárragos a la base del equipo con (1) arandela de ala ancha, (1) arandela grower y (1) tuerca en cada uno.

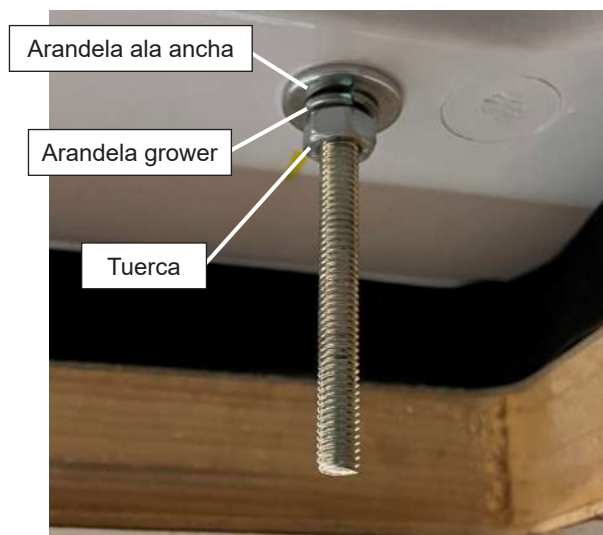
**9**

Montar (1) tuerca y (1) arandela de ala ancha en cada espárrago a una distancia aproximada de la base del enfriador de:

- Espesor de 30 mm: Entre 11 y 14 mm (\*)
- Espesor de 40 mm: Entre 21 y 24 mm
- Espesor de 50 mm: Entre 31 y 34 mm
- Espesor de 60 mm: Entre 41 y 44 mm

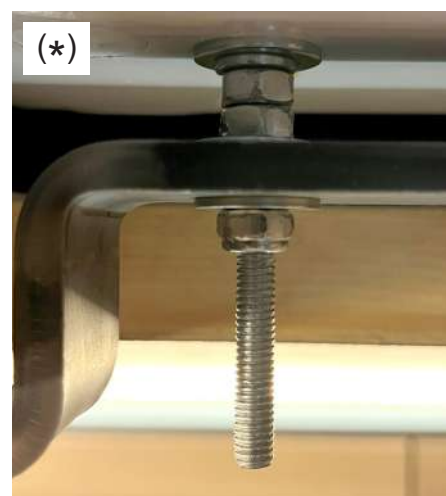
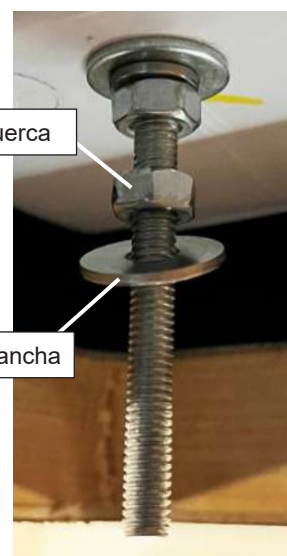
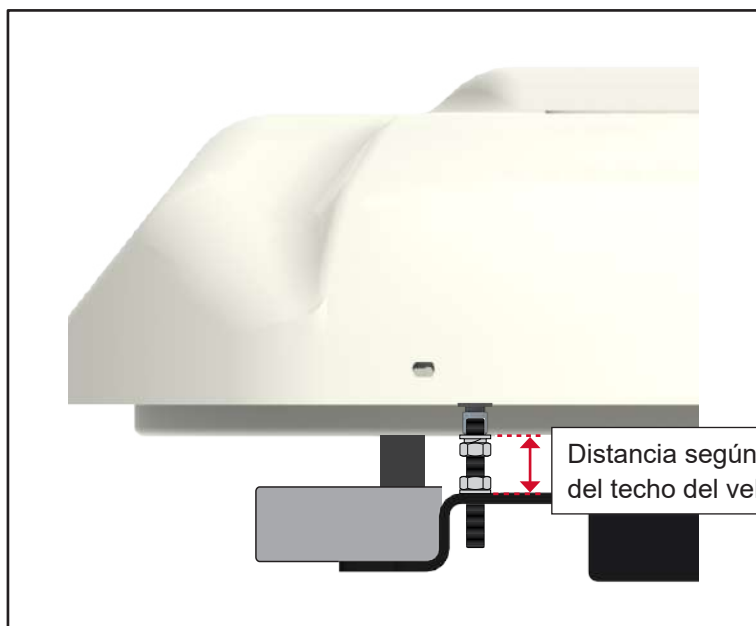

Detalle del montaje final del soporte de fijación en techo con espesor de 30 mm



10

Colocar soportes de fijación en los espárragos de la base del enfriador y fijar soportes con (1) arandela de ala ancha y (1) tuerca autoblocante en cada espárrago.

**Atención:** Los soportes de fijación deberán quedar montados en la posición que se indica.



Arandela ala ancha

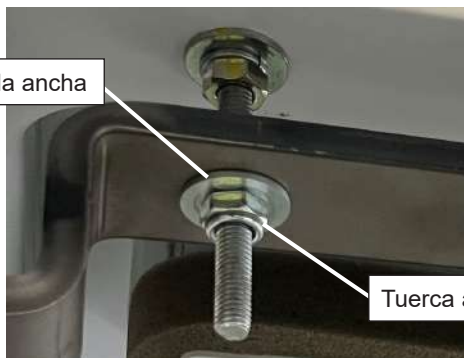

Tuerca autoblocante

11

Apretar tuercas autoblocantes de los soportes de fijación haciendo comprimir la junta EPDM exterior del techo entre 3 y 6 mm.

**Importante:** Para evitar posibles filtraciones de agua al interior del habitáculo se debe asegurar el apriete de la junta EPDM con la base del equipo tal y como se indica en el esquema de montaje (página 10).



Tuerca autoblocante

12

Apretar (4) tuercas superiores de los soportes para completar la fijación de los mismos.

**Importante:** Una vez apretados correctamente, los soportes deberán quedar planos respecto al techo. En caso de que esto no suceda, pueden aparecer dificultades durante el montaje de la consola interior.



Apretar tuerca

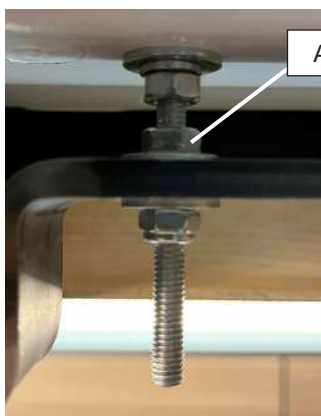

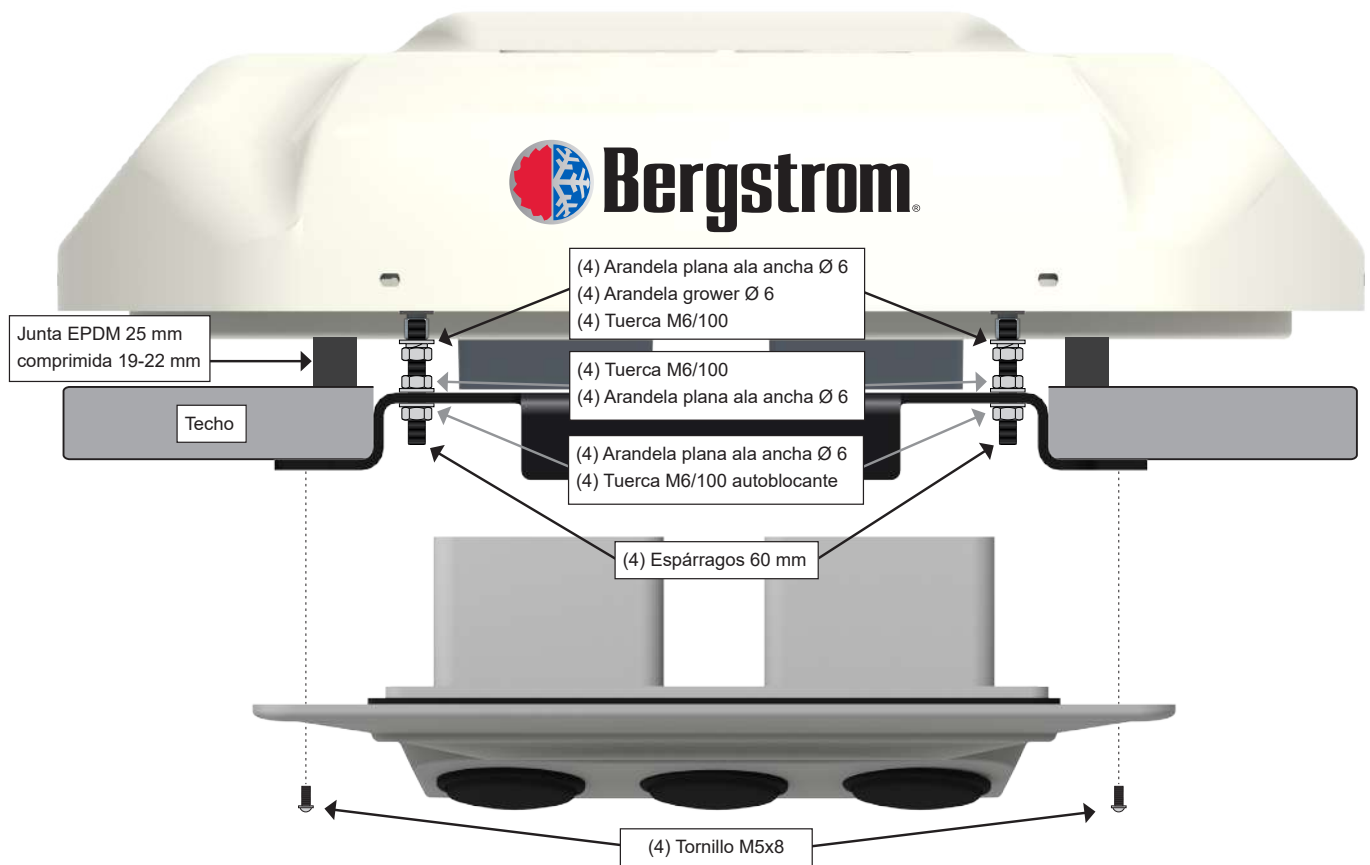
**ESQUEMA DE MONTAJE****13**

Conectar cableado de la consola interior al cableado del enfriador.



**14** Montar la consola interior con (4) tornillos M5x8.



**MONTAJE DEL CABLEADO DE ALIMENTACIÓN, CABLEADO DE SEÑAL A BATERÍA Y TUBO DE ENTRADA DE AGUA**

**15** Conectar cableado de alimentación, cableado de señal y tubo de entrada de agua al enfriador.

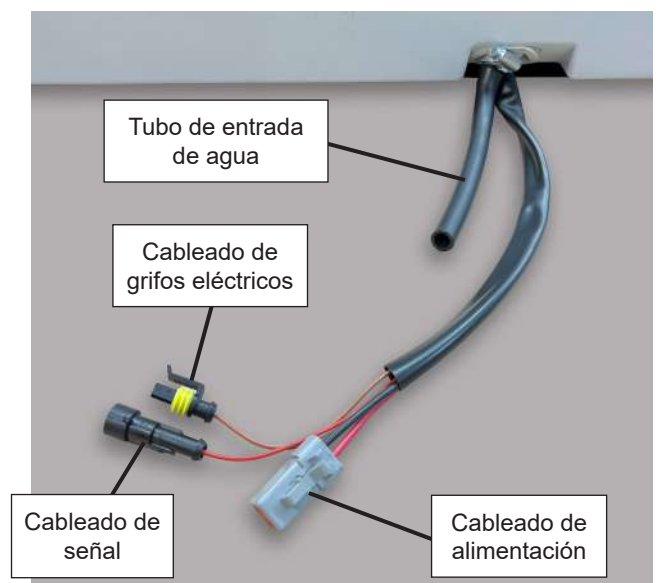
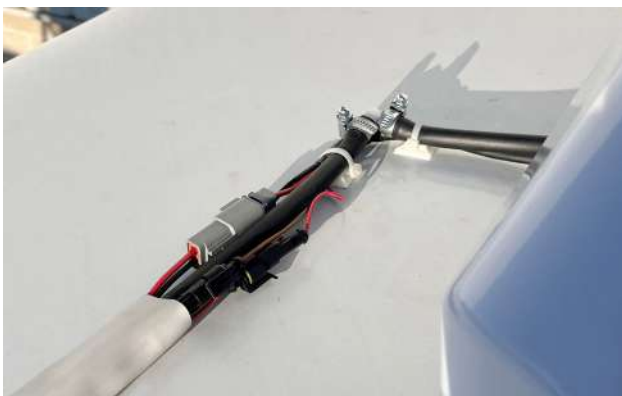

**16**

El instalador decidirá el mejor ruteado del cableado hasta la batería y del tubo de entrada de agua hasta el depósito del vehículo.

**17**

**EVER** dispone de un cubretuberías con el que proteger el acceso del cableado y el tubo de agua desde el techo al interior del vehículo.

Una vez instalado sellar con silicona o similar para evitar posibles entradas de agua al interior del vehículo.

**18**

Conectar tubo de entrada de agua del enfriador al depósito de agua del vehículo.

19

Si el vehículo dispone de grifos eléctricos será el instalador quien suministre e instale el cableado de activación de los grifos eléctricos o bomba de agua conectándolo al conector habilitado para tal efecto situado en la salida del enfriador.

Este conector suministra (-) 12V (negativo).

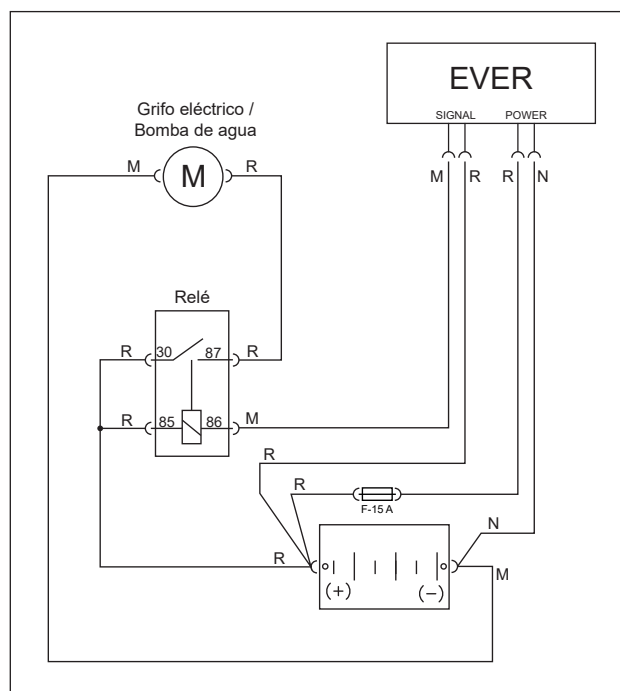

20

Conectar cableado de alimentación (positivo y negativo) a la batería. Conectar cableado de señal al positivo de la batería.

**Importante:** Para el buen funcionamiento del equipo, el cableado de alimentación debe conectarse directamente a la batería.

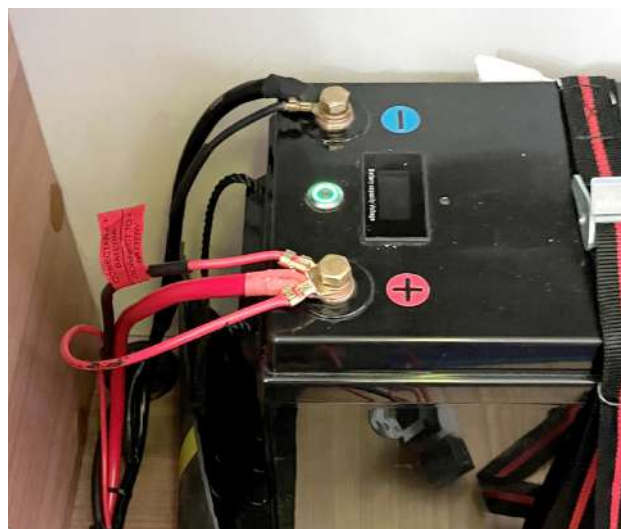

**Importante:** Antes de poner en funcionamiento el equipo, consultar el Manual del usuario, referencia: 1003652994 que puede encontrar en [www.bergstromspain.com](http://www.bergstromspain.com) para establecer una correcta configuración del equipo.



**ESQUEMA ELÉCTRICO**

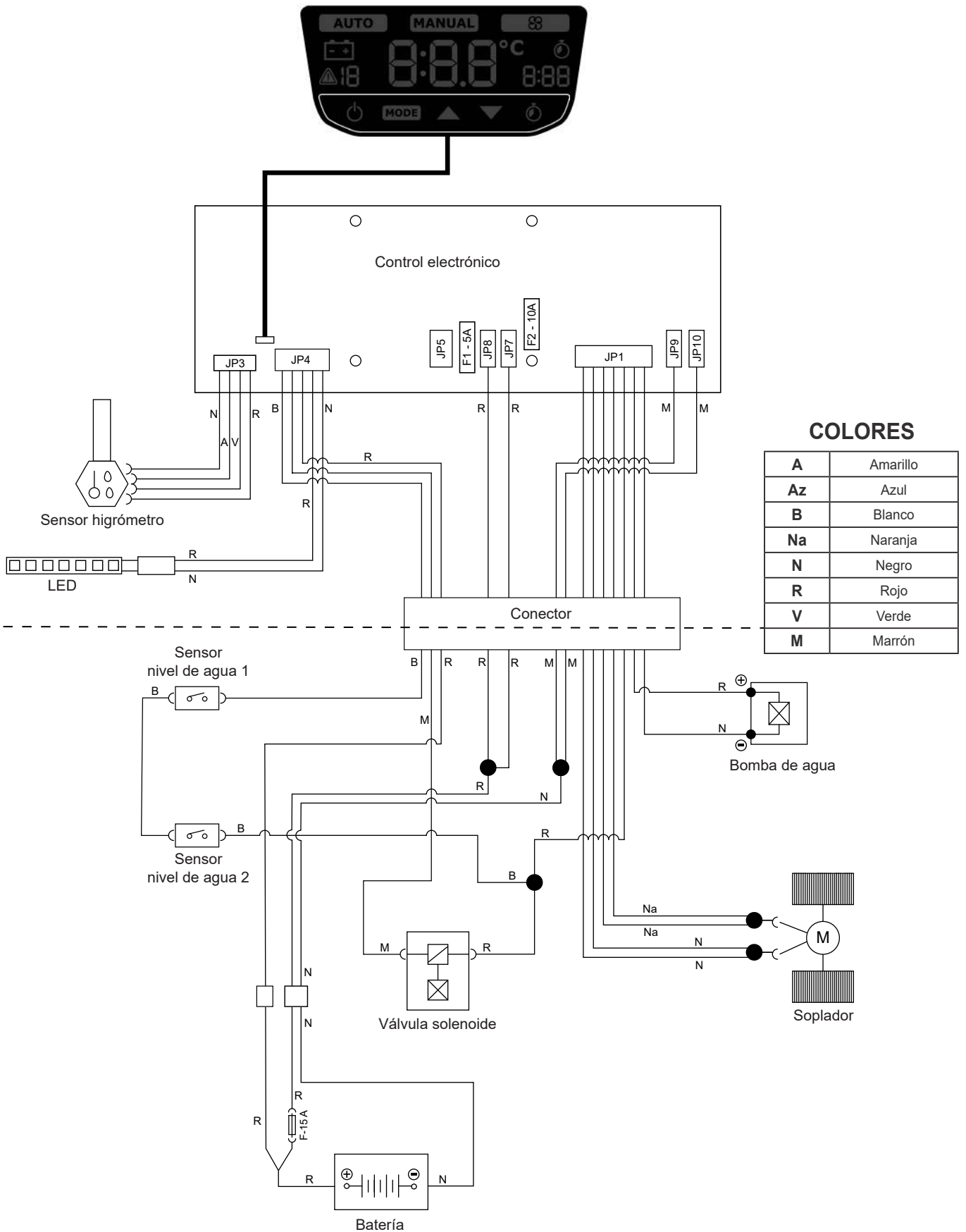



Thank you for placing your trust in our Caravaning range of products. **EVER** is a high-performance ecological roof cooler designed and manufactured by **Bergstrom** for use in motorhomes and other recreational vehicles, with or without the engine running. **EVER** is the best choice when it comes to keeping pets cool and safe.

**EVER** is designed with cutting-edge technology to achieve high performance, reduced fuel consumption and lower CO<sup>2</sup> emissions. These are the features that make it unique on the recreational vehicle cooling market.



**Read this document carefully before**

**installing the product.** Keep this document for future reference. The original documentation was written in Spanish, all other languages are translations.

All product manuals are available in digital version (PDF) at

<https://www.bergstromspain.com/>

All sales and warranty transactions are subject to the latest version of our general terms and conditions of sale, as published on our website

<https://www.bergstromspain.com/>

The manual includes the latest technological advances in this range at the time of publication. However, continuous improvement means there may be minor differences.

**Explanation of symbols**



- **Warning:** A safety alert indicating a situation which, if not avoided, could result in death or serious injury.



- **Hazard:** Cutting hazard. Indicates a situation that could lead to cuts.



- **Hazard:** Electrocution hazard. Indicates a situation that could lead to electrocution.



- **Alert:** Safety alert informing about a situation which, if not avoided, could result in damage to the unit or other materials.



- **Information:** Additional information on installing or handling the product.



- **Fragile:** Indicates a situation in which care must be taken to avoid damage to the unit and other materials.



**Explanation of liabilities**

- **Dirna Bergstrom** accepts no liability for any damage caused in the following cases:

- Damage to the product due to mechanical influences and surges.
- Modifications to the equipment without the manufacturer's express consent.
- Use of the equipment for purposes not described in this document.
- Improper handling or installation of the cooler.

- When installing **EVER** on the roof, bear in mind that vehicles with a skylight normally have a structure strong enough to withstand the weight of the unit. When installing a skylight or cutting into the roof, if materials such as fibreglass or plastic do not offer the necessary strength, **the installer is responsible** for evaluating the need to reinforce the roof to prevent any deformation, breakage, or water ingress, and to provide the necessary means to address these issues.

**EVER** is a versatile cooler that can also be installed rotated 180° in order to adapt to the available space on the vehicle's roof and ensure it does not interfere with the rest of the installed accessories.



**Warnings during assembly**

- This equipment may only be installed, repaired, and maintained by technical personnel with due training in vehicle air conditioning, potential hazards and applicable standards.
- Read the instructions carefully before installing the cooler. Follow the instructions carefully during installation.
- Turn off the ignition before starting to install the cooler.
- Disconnect the vehicle's battery before starting to install the cooler.
- Install **EVER** securely to prevent it from falling.
- Use appropriate tools for each operation.
- During installation, ensure the connection of the electrical components, checking that they are fitted correctly.
- If the cable passes through sharp-edged walls during installation, use ducts or guides to prevent any damage to it.



- **Important:** Be careful not to reverse the polarities when connecting the cooler. If this happens, the control board will not come on and the unit will not work.
- Once the cooler is installed, the winter covers, and the quick guide should be handed over to the user.





### Recommended tools for assembly

- Thorx 10 Phillips screwdriver.
- Flat screwdriver.
- 10 mm open-end wrench.
- Flexometer.
- Scroll saw.
- Cutter.



### Proper use of the product

- **EVER** is a high-performance ecological roof cooler suitable for use in caravans and other recreational vehicles. It is not suitable for installation and operation in agricultural or construction machinery that is subject to intense vibrations.
- To ensure the unit works properly, it is best to keep the vehicle level, or, failing this, to place the front of the cooler at the highest point. If warning   appears on the screen, AUTO or MANUAL mode will reactivate once the vehicle is level.
- Using it in any way other than as envisaged will void the cooler's warranty and exempt the manufacturer from any liability.
- See the product's user manual if you are not sure how to use **EVER**.



### Associated documentation

- Quick guide: 1003653001
- User manual: 1003652994
- List of spare parts: 1003652997
- Troubleshooting: 1003652996

**Dirna Bergstrom** uses excellence assurance processes in accordance with international quality management standards ISO 9001, Automotive Quality IATF 16949, and Environmental Management ISO 14001 to ensure the highest quality of its products. Certified by IQNet Quality System.

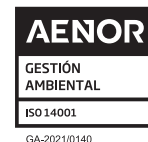

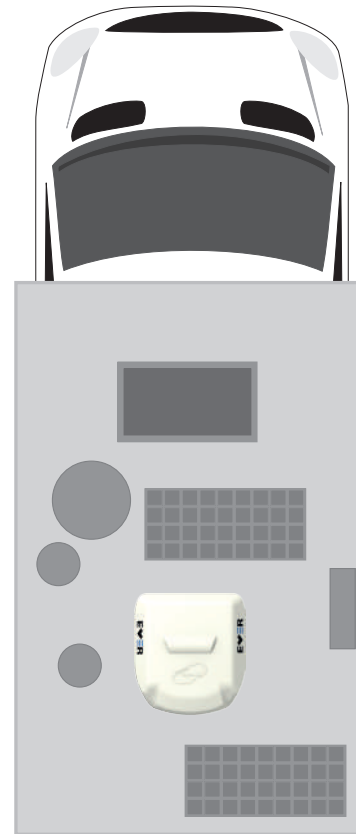
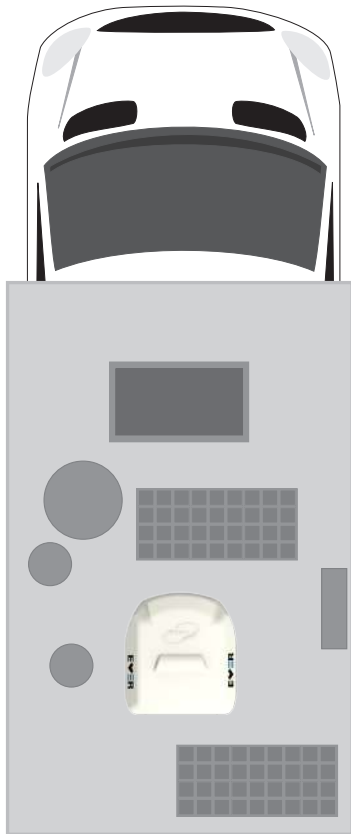
**ASSEMBLY OPTIONS**

**Caution:** A clearance of at least 10 cm unit must be maintained around the unit to ensure proper ventilation and prevent poor performance.

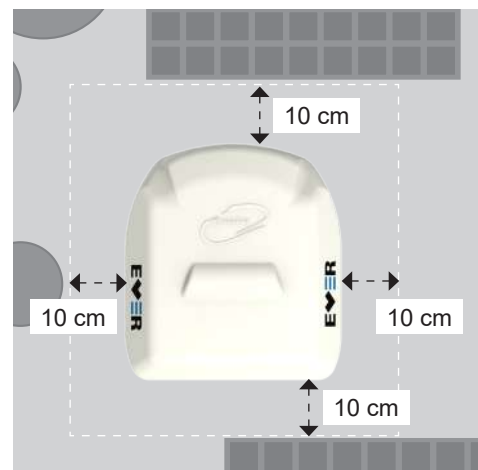



# OPERATIONS BEFORE INSTALLING THE EVER COOLER IN VEHICLES WITH NO ROOF HATCH

**1** Take the cutting template from the **EVER** equipment box and place it on the roof of the vehicle to mark the position where the cooler will be installed.

**Caution:** Check that the marking on the outside does not interfere with any element inside the vehicle when mounting the cooler's interior console.

**Note:** **EVER** is a versatile cooler that can also be installed rotated 180° in order to adapt to the available space on the vehicle's roof and ensure it does not interfere with the rest of the installed accessories.

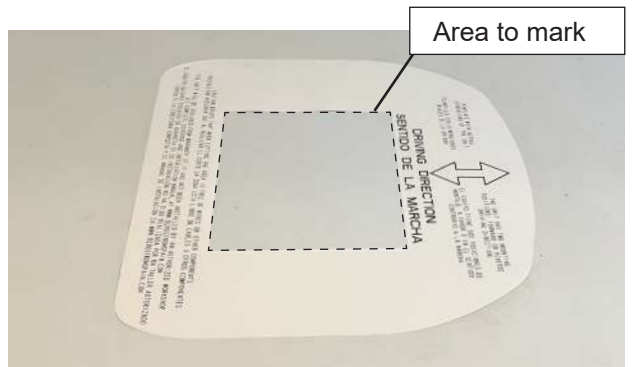

**2** From outside the vehicle, mark the 400 x 400 mm space where the cooler will sit. Drill (1) hole in each of the 4 corners of the marked space.

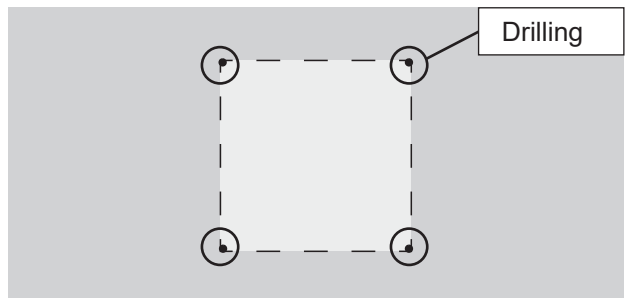

**3** From outside the vehicle, join the holes by cutting the roof using a jigsaw. Complete the cut from the inside by cutting the batting and the false ceiling.

**Caution:** Take care when making the cut, as there may be a cable duct inside.



## REQUIREMENTS TO INSTALL THE EVER COOLER IN VEHICLES WITH A ROOF HATCH



**Caution:** **EVER** can only be installed in vehicles with a hatch that are equipped with:

- 400 x 400 mm roof opening
- Roof 30 to 60 mm thick

**4**

Remove the hatch and the frame of the vehicle where the **EVER** cooler will be installed.



## EVER COOLER INSTALLATION PROCESS

**5**

Place the EPDM seal around the hatch opening or the cut.





**HOW TO CUT EPDM GASKET TO AVOID WATER FILTRATION INTO THE CABIN**

- A- Glue gasket, keeping 100 mm of protection paper at each side.
- B- Remove the two pieces of paper.
- C- Glue by pressing both ends.

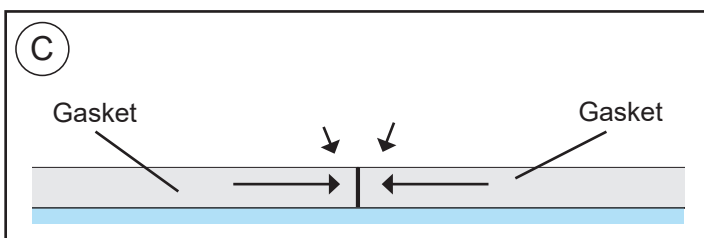
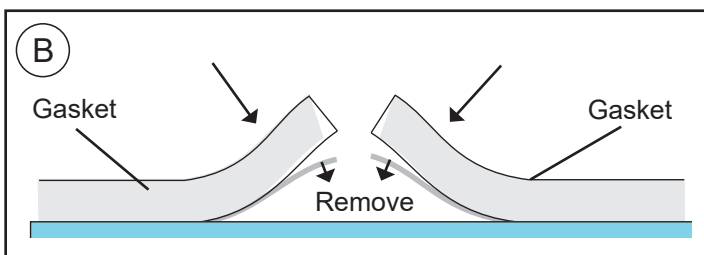
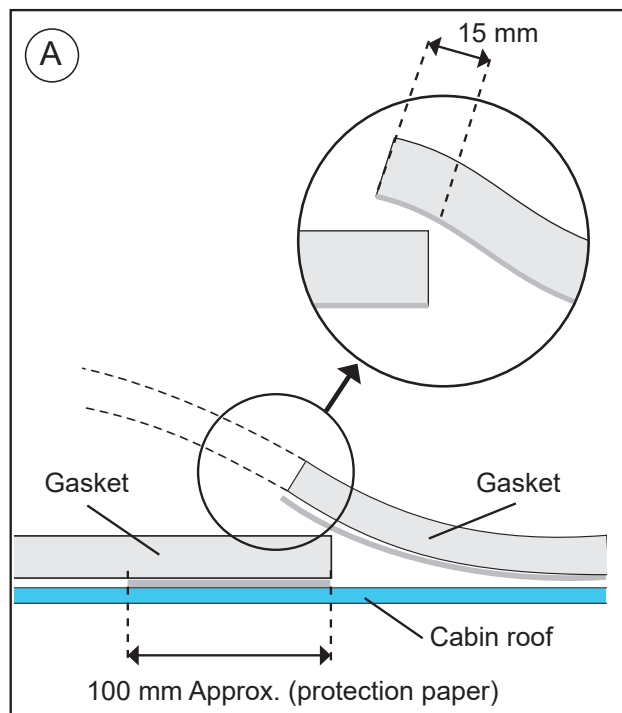

**6**

Place the cooler on the assembly seal by aligning it to the roof opening from inside the vehicle, ensuring that the (4) fastening points of the cooler base brackets are aligned in the roof opening.



**7**

Install (4) 60 mm studs at the cooler base fastening points.



**8**

Fasten the (4) studs to the base on the unit with (1) wide-rimmed washer, (1) grower washer and (1) nut on each one.

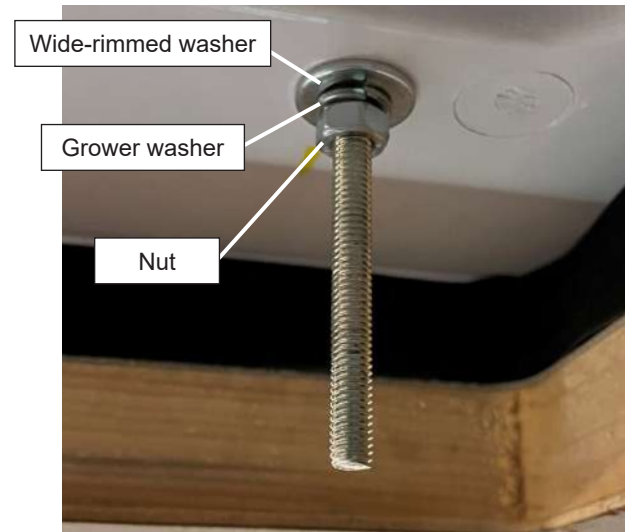
**9**

Mount (1) nut and (1) wide-rimmed washer on each stud at the following approximate distances from the base of the cooler:

- 30 mm thick: Between 11 and 14 mm (\*)
- 40 mm thick: Between 21 and 24 mm
- 50 mm thick: Between 31 and 34 mm
- 60 mm thick: Between 41 and 44 mm

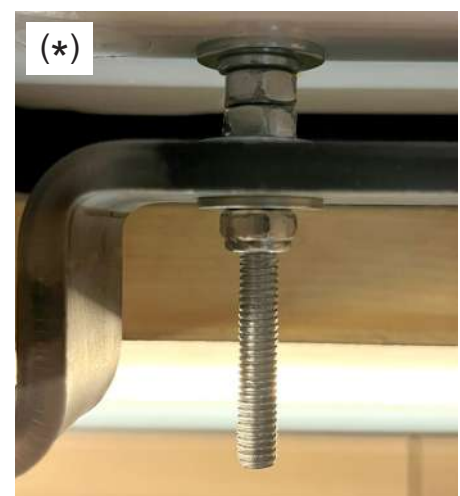
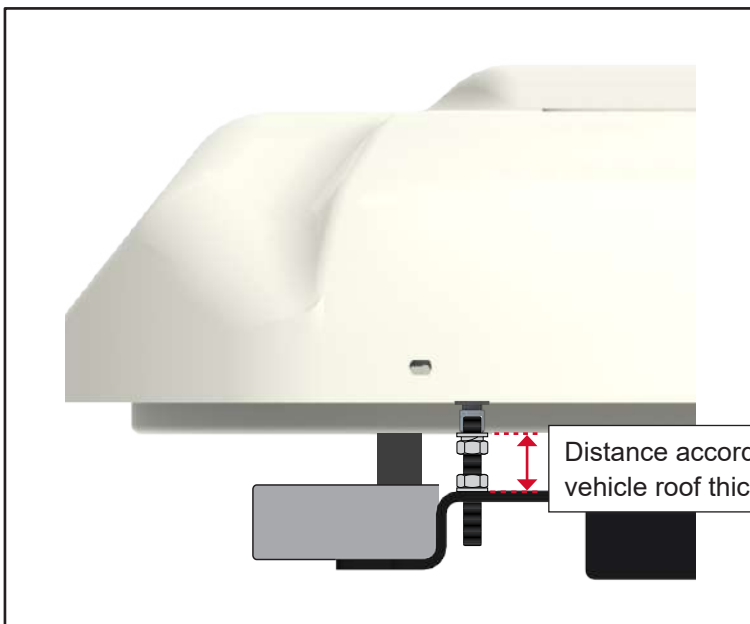
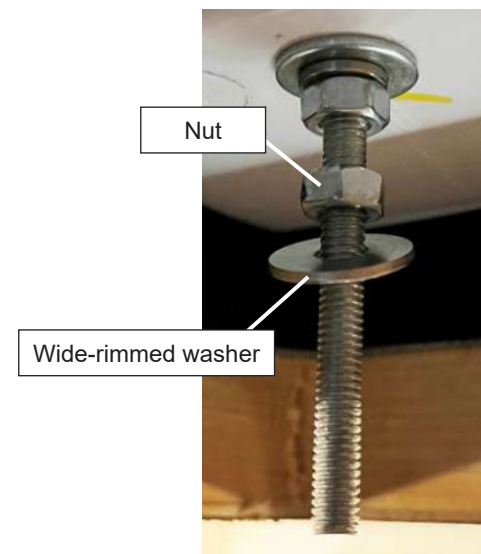

Detail of the final fastening bracket assembly on a 30 mm-thick roof

10

Place fastening brackets on the studs on the base of the cooler and fasten the brackets with (1) wide-rimmed washer and (1) self-locking nut on each stud.

**Caution:** The fastening brackets must be mounted in the position shown.



Wide-rimmed washer

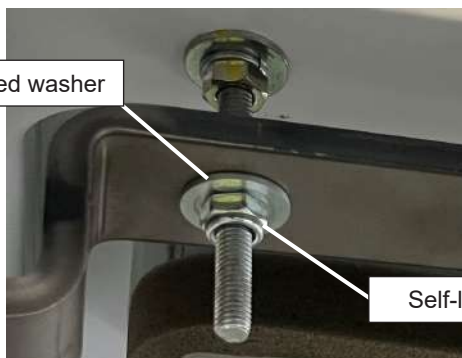

Self-locking nut

11

Tighten the self-locking nuts of the fastening brackets by compressing the roof's outer EPDM seal between 3 and 6 mm.

**Important:** The EPDM seal must be tight with the base of the unit in order to prevent any ingress of water inside the cabin, as shown in the assembly diagram (page 24).



Self-locking nut

12

Tighten (4) top nuts of the brackets to complete the fastening process.

**Important:** The brackets should be fastened securely to the roof, ensuring they remain flush and level. Any other situations may lead to problems when installing the interior console.



Tighten the nut

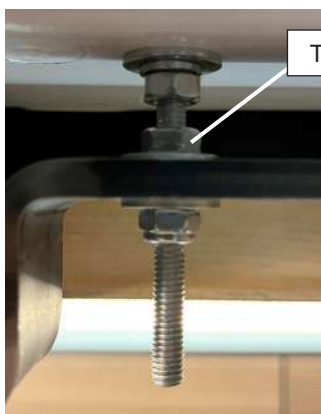

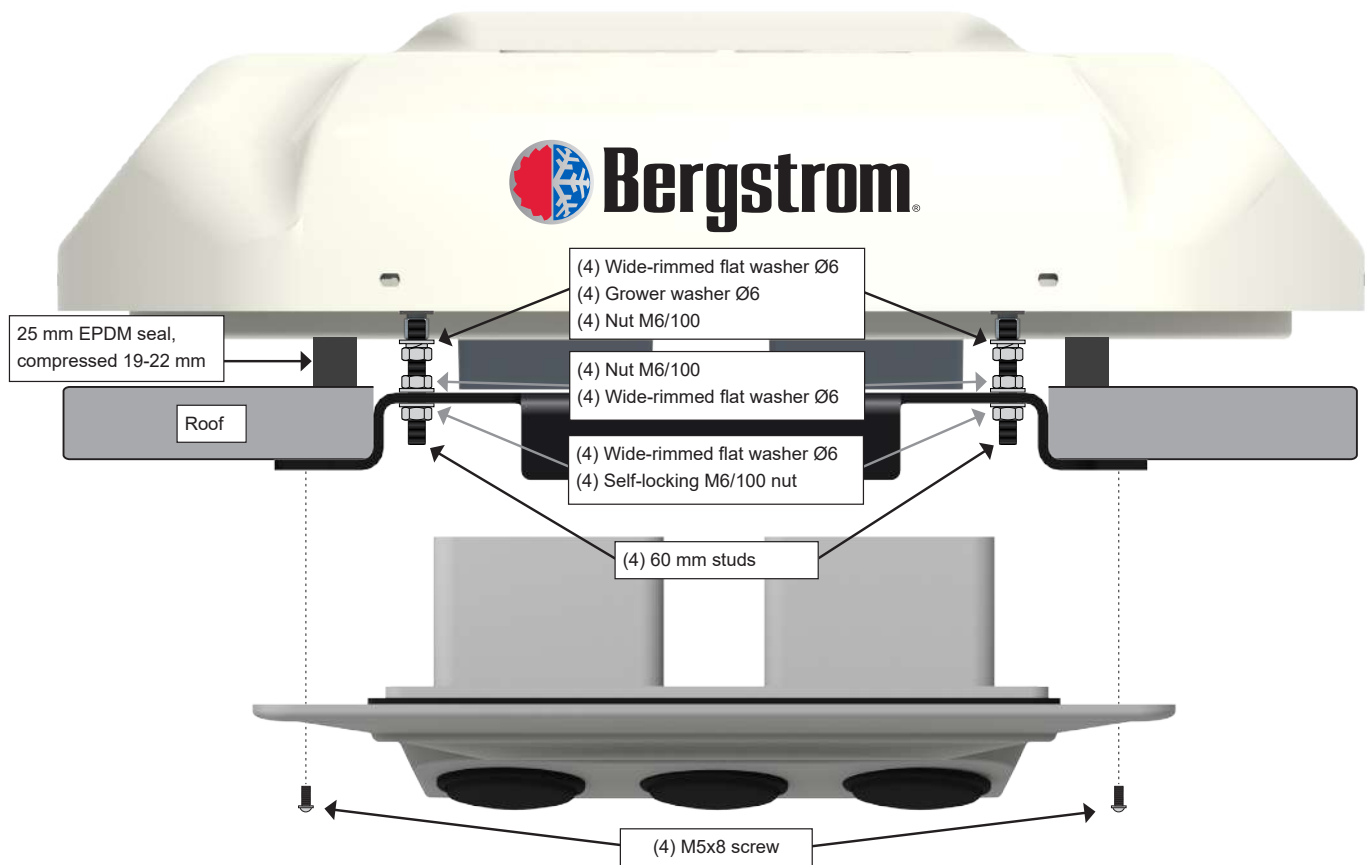

**ASSEMBLY DIAGRAM****13**

Connect the interior console cables to the cooler cables.

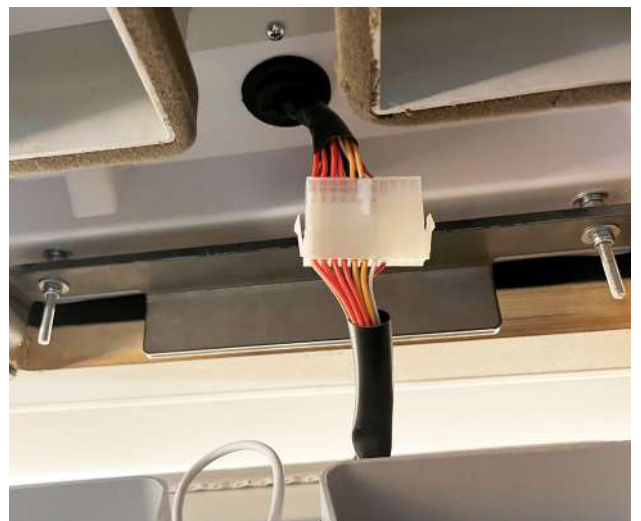

14

Mount the interior console with (4) M5x8 screws.



**POWER CABLES, SIGNAL CABLES TO BATTERY, AND WATER INPUT PIPE ASSEMBLY**

15

Connect the power and signal cables, and the water input pipe to the cooler.

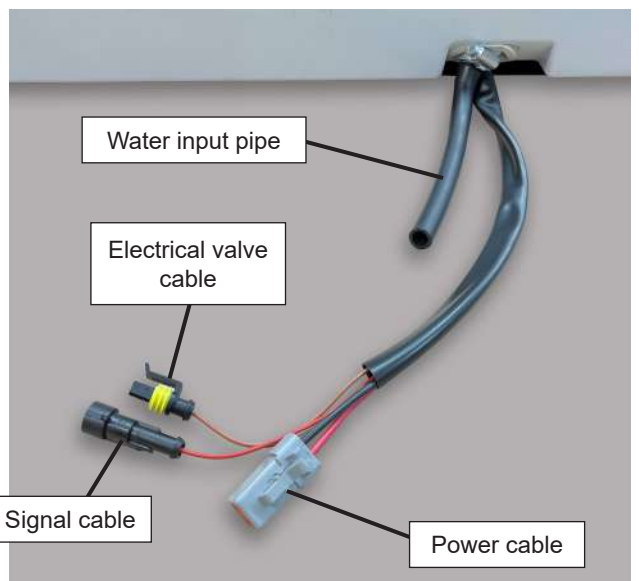
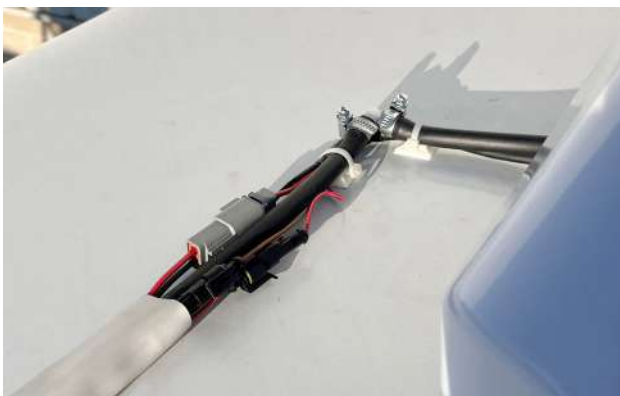

**16**

The installer will decide the best route for the cables to the battery and the water input pipe to the vehicle's tank.

**17**

**EVER** has a pipe cover to protect the cable input and the water pipe from the roof to inside the vehicle.

Once installed, seal with silicone or similar to prevent any water ingress into the vehicle.

**18**

Connect the cooler's water input pipe to the vehicle's water tank.

19

If the vehicle has electric taps, the installer will supply and install the activation cables for the electric taps or water pump, connecting them to the designated connector at the cooler's outlet.

This connector supplies (-) 12V (negative).

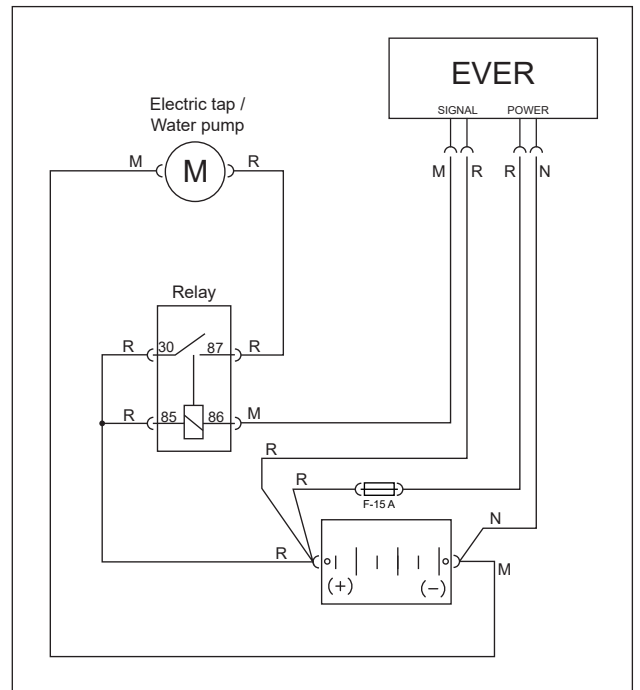

20

Connect the power cables (positive and negative) to the battery. Connect signal cables to the battery's positive.

**Important:** The power cables must be connected directly to the battery in order for the equipment to work correctly.

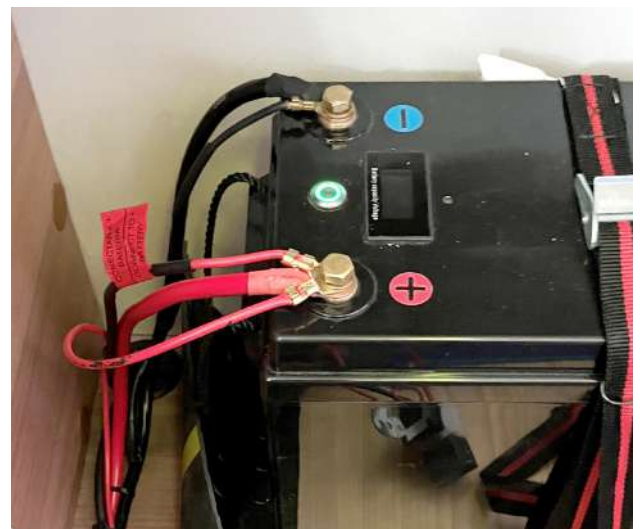

**Important:** Before starting up the unit, see the User Manual (reference 1003652994) at [www.bergstromspain.com](http://www.bergstromspain.com) to ensure it is configured correctly.

**WIRING DIAGRAM**

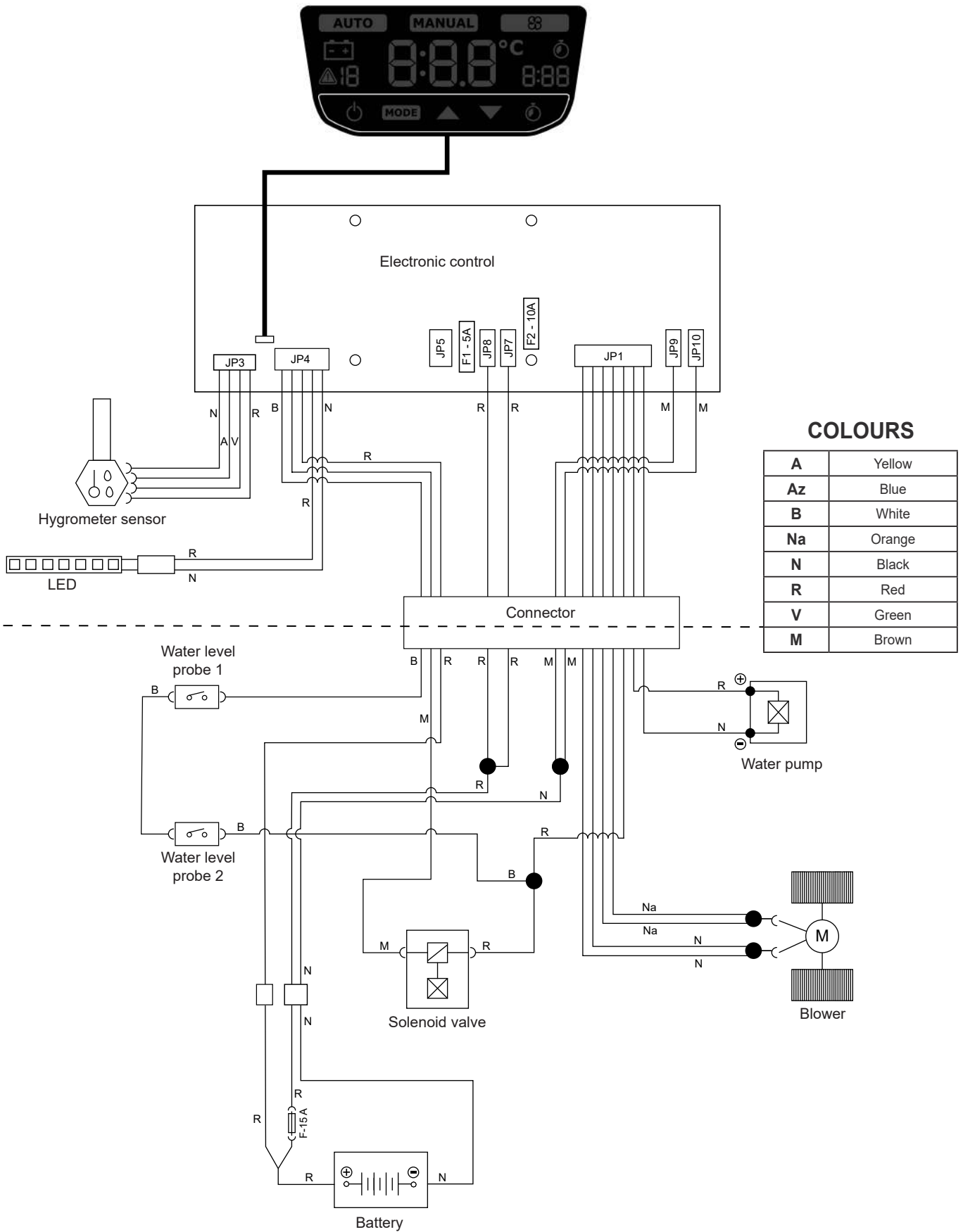





Nous vous remercions de votre achat et de la confiance témoignée à notre gamme de produits Caravaning. **EVER** est un refroidisseur de toit écologique et performant conçu et fabriqué par **Bergstrom** pour être utilisé dans les camping-cars et autres véhicules de loisirs motorisés à l'arrêt ou en mouvement. **EVER** est la meilleure option permettant que les animaux de compagnie se sentent en sécurité et au frais.

**EVER** est conçu avec la technologie la plus avancée pour obtenir des performances efficaces, une consommation réduite de carburant et diminuer les émissions de CO<sup>2</sup> dans l'atmosphère. Ce sont ces caractéristiques qui le rendent unique sur le marché de la réfrigération pour véhicules de loisir.



**Veillez lire attentivement ce document avant d'installer le produit.** Conservez ce document pour toute référence ultérieure.

La documentation d'origine a été rédigée en espagnol, les autres langues sont donc des traductions.

Vous avez à votre disposition tous les manuels des produits dans leurs versions numériques (PDF) sur <https://www.bergstromspain.com/>

Toute opération de vente ou de garantie est soumise à nos conditions générales de vente dans leur version la plus à jour, publiée sur notre site Web <https://www.bergstromspain.com/>

Ce manuel reflète les derniers progrès techniques de cette gamme au moment de la publication. Toutefois il peut exister quelques différences en raison du perfectionnement continu.

### Explication des symboles



- **Avertissement** : Avis de sécurité informant d'une situation qui, si elle n'est pas évitée, pourrait conduire à des blessures graves ou la mort.



- **Danger** : Risque de coupure. Signale une situation qui pourrait conduire à une coupure.



- **Danger** : Risque d'électrocution. Signale une situation qui pourrait conduire à une électrocution.



- **Avertissement** : Avis de sécurité informant d'une situation qui, si elle n'est pas évitée, pourrait entraîner des dommages matériels (appareil ou autre).



- **Information** : Information complémentaire sur l'installation ou la manipulation du produit.



- **Fragile** : Indique une situation dans laquelle il faut procéder avec précaution afin de ne pas endommager l'unité ou d'autre matériel.



### Explication des responsabilités

- **Dirna Bergstrom** décline toute responsabilité en termes de dommages causés dans les cas suivants :

- Dommages au produit dus à des influences mécaniques et à des surtensions.
- Modifications apportées à l'unité sans le consentement exprès du fabricant.
- Utilisation de l'unité à des fins non décrites dans ce document.
- Manipulation ou installation inappropriée du refroidisseur.

- Lors de l'installation d'**EVER** sur le toit, tenir compte du fait que généralement les véhicules, qui sont dotés d'une trappe, possèdent la structure suffisante pour supporter le poids de l'appareil. Cependant, lorsque ce n'est pas le cas et qu'il est nécessaire de faire une découpe dans le toit, ou même dans le cas d'une lucarne, le matériau n'est pas suffisamment résistant (toits en fibre, plastique, etc.), **l'installateur doit décider**, sous sa responsabilité, de la nécessité de le renforcer pour éviter d'éventuelles déformations, ruptures, infiltrations d'eau, etc. en prévoyant les moyens nécessaires pour que cela ne se produise pas.

**EVER** est un refroidisseur polyvalent qui peut également être installé avec une rotation de 180° afin de l'adapter à l'espace disponible sur le toit du véhicule et de ne pas interférer avec le reste des accessoires installés.



### Mises en garde au cours du montage

- L'installation, la réparation et l'entretien de cette unité, ne peuvent être réalisés que par un personnel technique suffisamment formé sur la climatisation des véhicules, les dangers éventuels et les normes applicables.
- Lire attentivement les consignes de montage avant de commencer l'installation du refroidisseur. Pendant l'installation, suivre au pied de la lettre les consignes indiquées.

- Retirer la clé de contact avant de commencer l'installation de l'équipement.
- Débrancher la batterie du véhicule avant de commencer l'installation du refroidisseur.
- Installer **EVER** en toute sécurité afin d'éviter les chutes.
- Utiliser les outils appropriés à chaque opération.
- Pendant l'installation, s'assurer du raccordement des composants électriques en vérifiant leur bon ajustement.
- Si lors de l'installation des câbles traversent des murs à arêtes vives, utiliser des conduits ou des dispositifs de guidage, afin d'éviter l'endommagement des câbles.



- **Avertissement important** : Faites attention lors du raccordement du refroidisseur à ne pas inverser les polarités. Si cela se produit, la carte de commande ne s'allumera pas et l'unité ne se mettra pas en marche.
- Une fois le refroidisseur installé, les couvercles d'hiver et le guide rapide du produit devront être remis à l'utilisateur.





### Outils recommandés pour le montage

- Tournevis cruciforme thorx 10.
- Tournevis plat.
- Clé plate de 10.
- Flexomètre.
- Scie sauteuse.
- Cutter.



### Utilisation appropriée du produit

- **EVER** est un refroidisseur à haute performance à monter sur le toit, apte pour être utilisé dans les camping-cars et autres véhicules de loisirs. Il n'est pas apte pour être installé ou fonctionner sur des machines agricoles ou de construction soumises à des vibrations intenses.
- Pour assurer le fonctionnement correct de l'appareil, il est recommandé de maintenir le véhicule en position horizontale ou, si cela n'est pas possible, de placer l'avant du refroidisseur dans la position la plus élevée. Si l'avertissement   apparaît sur l'écran, le mode AUTO ou MANUEL sera réactivé une fois que le véhicule sera mieux nivelé.

- L'utilisation non conforme à l'usage prévu annule la garantie du refroidisseur et exclut la responsabilité du fabricant.
- Si vous n'êtes pas sûr de comment utiliser **EVER**, consultez la notice du produit.



### Documentation connexe

- Guide rapide : 1003653001
- Mode d'emploi : 1003652994
- Liste de pièces de rechange : 1003652997
- Diagnostic de pannes : 1003652996

Conformément aux normes internationales de gestion de la qualité ISO 9001, de qualité automobile IATF 16949 et de gestion de l'environnement ISO 14001, **Dirna Bergstrom** utilise des processus d'assurance de l'excellence pour garantir la plus haute qualité de ses produits. Certifiée par IQNet Quality System.



**OPTIONS DE MONTAGE**

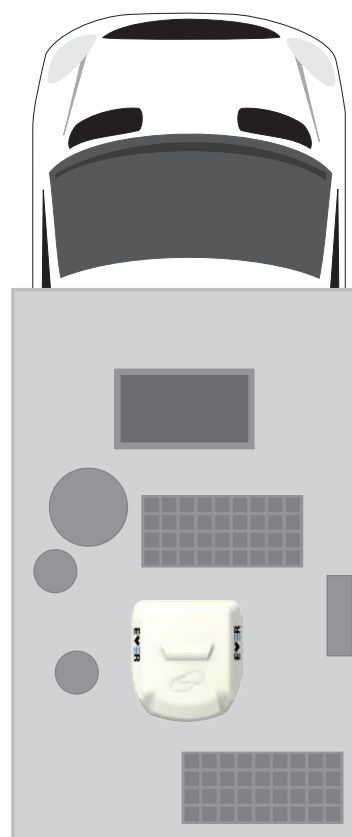
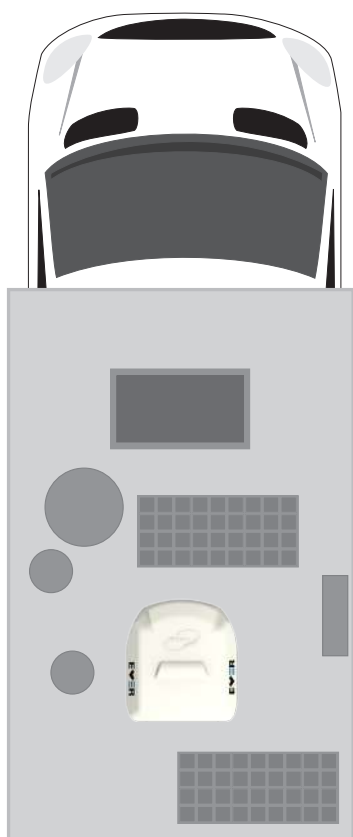

**Attention** : Afin d'assurer une bonne ventilation de l'appareil et d'éviter tout dysfonctionnement, un espace d'au moins 10 cm doit être laissé libre autour de l'appareil.

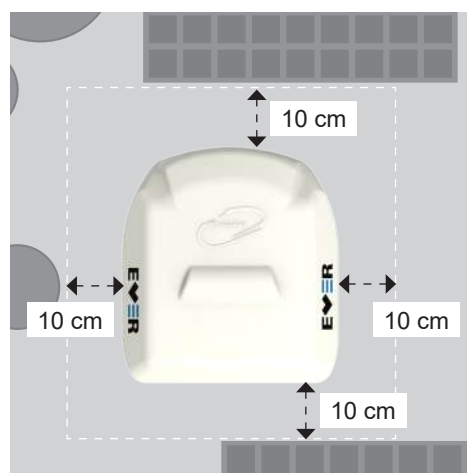

# OPÉRATIONS PRÉALABLES À L'INSTALLATION DU REFROIDISSEUR EVER SUR DES VÉHICULES DÉPOURVUS DE TRAPPES DE TOIT

**1** Prendre le modèle de découpe situé dans la boîte d'équipement **EVER** et le présenter sur le toit du véhicule pour marquer la position correcte où le refroidisseur sera installé.

**Attention :** Vérifier que la marque faite à l'extérieur n'interfère avec aucune partie de l'intérieur du véhicule pour le montage de la console intérieure du refroidisseur.

**Remarque :** **EVER** est un refroidisseur polyvalent qui peut également être installé avec une rotation de 180° afin de l'adapter à l'espace disponible sur le toit du véhicule et de ne pas interférer avec le reste des accessoires installés.

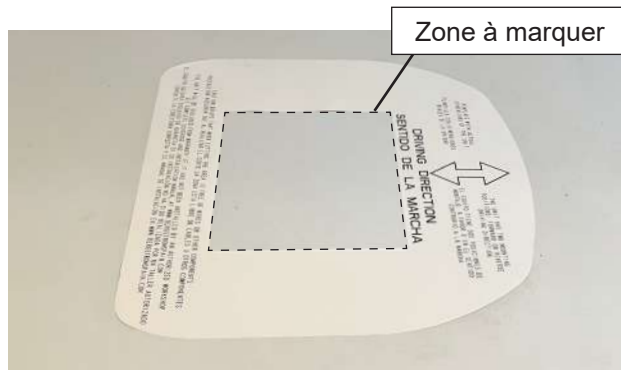

**2** Depuis l'intérieur du véhicule, marquer l'espace de 400 x 400 mm où le refroidisseur sera installé. Percer (1) trou aux 4 coins de l'espace marqué.

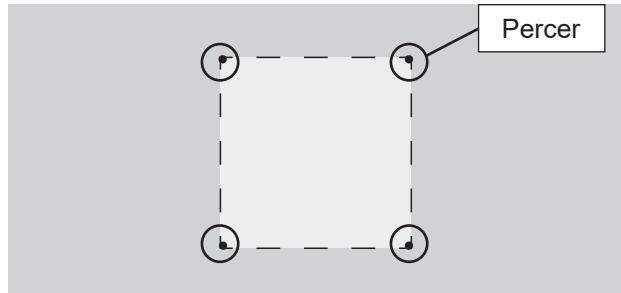

**3** Depuis l'extérieur du véhicule, rejoindre les trous en découpant le toit à l'aide d'une scie sauteuse. Compléter la coupe de l'intérieur en découpant la ouate et le faux plafond.

**Attention :** Soyez prudent lors de la découpe car vous risquez de rencontrer un passage de câbles.



## CONDITIONS POUR L'INSTALLATION DU REFROIDISSEUR EVER DANS LES VÉHICULES ÉQUIPÉS DE TRAPPES DE TOIT



**Attention :** EVER ne peut être installé que dans les véhicules équipés d'une trappe qui ont :

- une ouverture de toit de 400 x 400 mm
- une épaisseur de toit de 30 à 60 mm

**4**

Démonter la trappe et le cadre du véhicule où le refroidisseur **EVER** doit être placé.



## PROCESSUS D'INSTALLATION DU REFROIDISSEUR EVER

**5**

Placer le joint de montage EPDM autour de l'ouverture ou de la découpe de la trappe.





**COMMENT COUPER LE JOINT EPDM POUR A EVITER LES FILTRATIONS DANS LA CABINE**

- A- Coller le joint en maintenant une protection en papier de 100 mm de chaque côté.
- B- Retirer les deux morceaux de papier.
- C- Coller en faisant pression sur les deux extrémités.

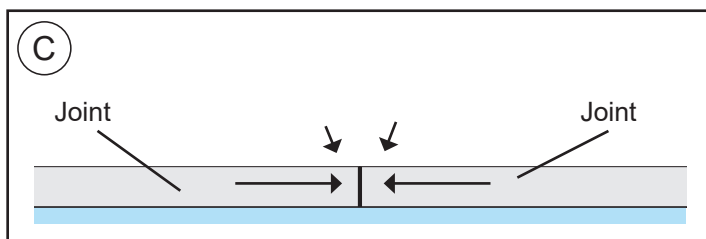
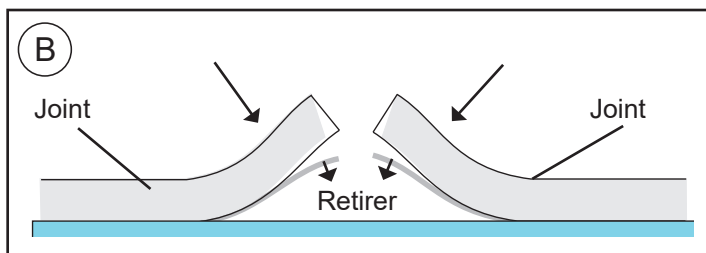
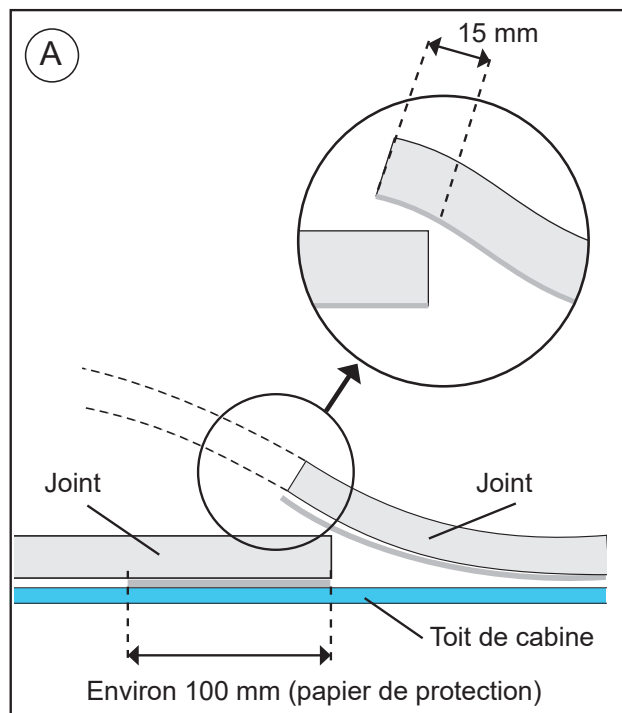

**6**

Positionner le refroidisseur sur le joint de montage en le centrant sur l'ouverture du toit depuis l'intérieur du véhicule en veillant à ce que les (4) points de fixation des supports de la base du refroidisseur soient centrés dans l'ouverture du toit.



**7**

Fixer (4) goujons de 60 mm aux points de fixation de la base du refroidisseur.





**8**

Fixer les (4) goujons à la base de l'unité avec (1) rondelle à surface large, (1) rondelle grower et (1) écrou sur chacune d'elles.

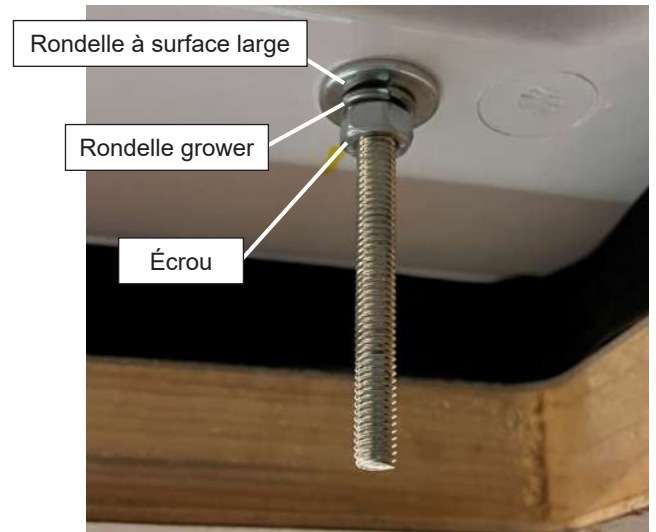

Rondelle à surface large

Rondelle grower

Écrou

**9**

Monter (1) écrou et (1) rondelle à surface large sur chaque goujon à une distance approximative de la base du refroidisseur de :

- Épaisseur de 30 mm : Entre 11 et 14 mm (\*)
- Épaisseur de 40 mm : Entre 21 et 24 mm
- Épaisseur de 50 mm : Entre 31 et 34 mm
- Épaisseur de 60 mm : Entre 41 et 44 mm

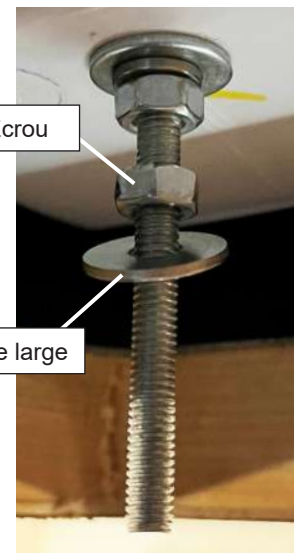

Écrou

Rondelle à surface large

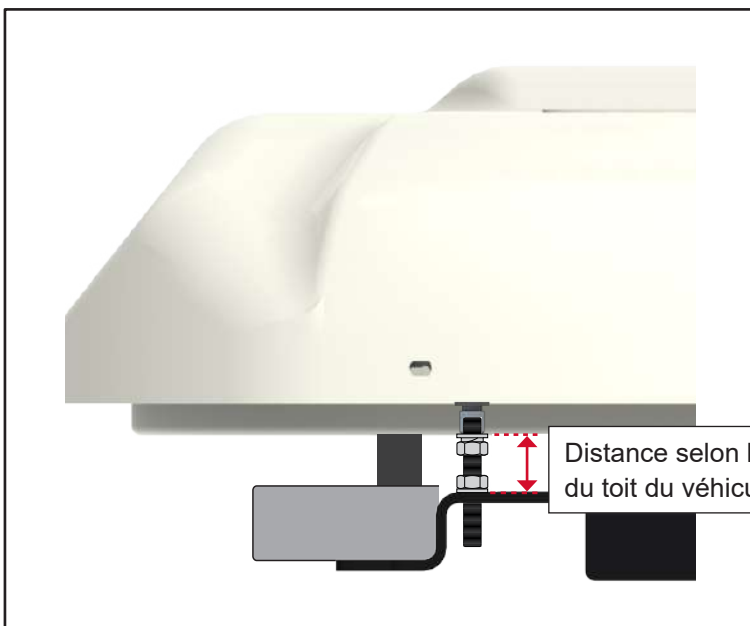

Distance selon l'épaisseur du toit du véhicule

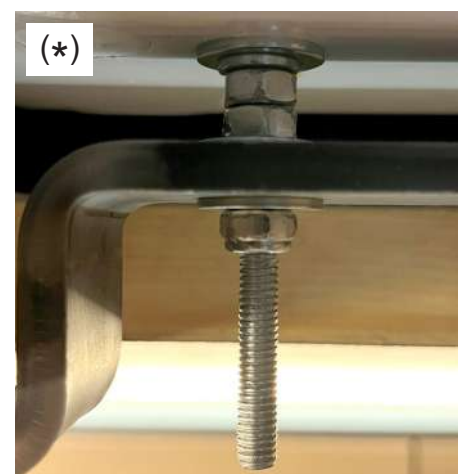

(\*)

Détail du montage final du support de fixation dans le toit avec une épaisseur de 30 mm

10

Placer les supports de fixation sur les goujons de la base du refroidisseur et fixer les supports avec (1) rondelle à surface large et (1) écrou autobloquant sur chaque goujon.

**Attention :** Les supports de fixation devront être montés sur la position indiquée.



Rondelle à surface large

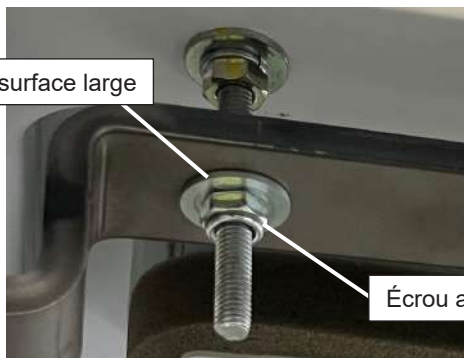

Écrou autobloquant

11

Serrer les écrous autobloquants des supports de fixation en comprimant le joint EPDM extérieur du toit entre 3 et 6 mm.

**Important :** Pour éviter d'éventuelles fuites d'eau à l'intérieur de l'habitacle, veillez à ce que le joint EPDM soit serré à la base de l'appareil comme indiqué sur le schéma de montage (page 38).



Écrou autobloquant

12

Serrez les (4) écrous supérieurs des supports pour compléter la fixation de ces derniers.

**Important :** Une fois correctement serrés, les supports doivent être posés à plat sur le toit. Si ce n'est pas le cas, des difficultés peuvent survenir lors du montage de la console intérieure.

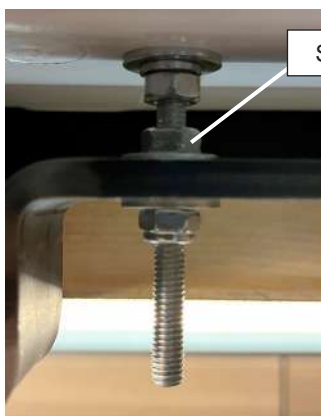

Serrez l'écrou

**SCHÉMA DE MONTAGE**

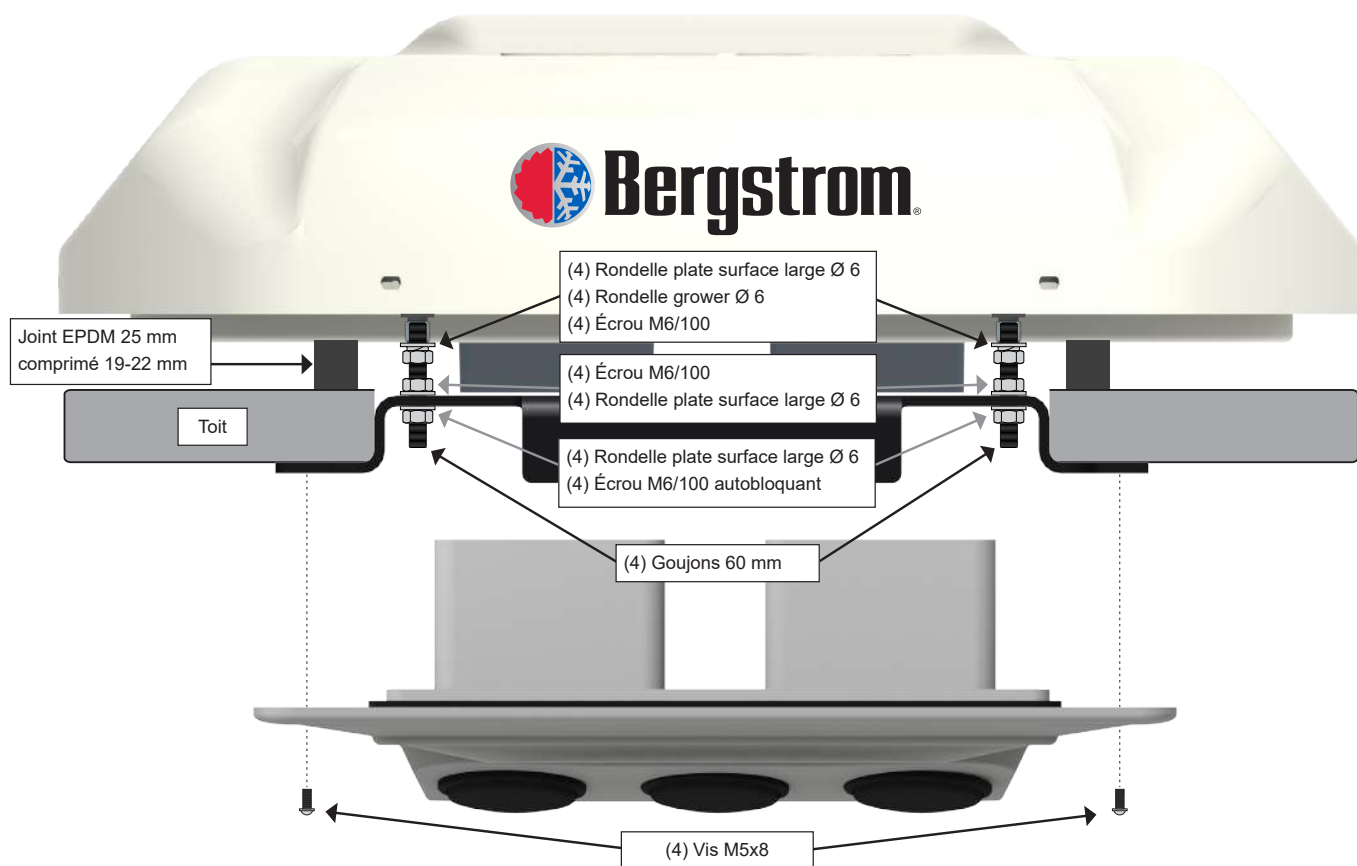

**13** Connecter le câblage de la console intérieure au câblage du refroidisseur.

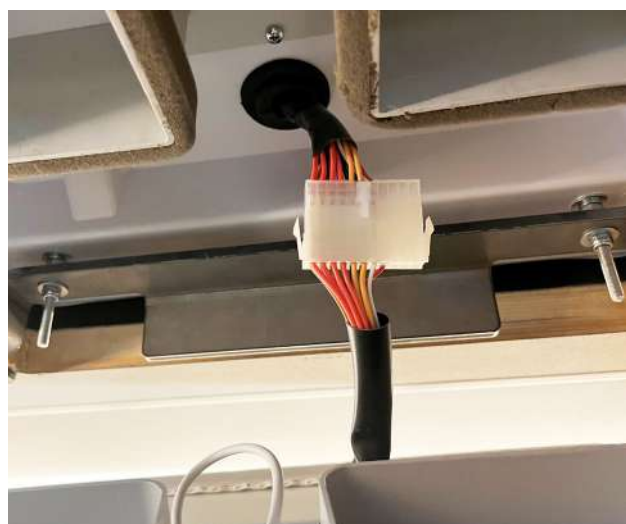

14

Monter la console intérieure avec (4) vis M5x8.



## MONTAGE DU CÂBLAGE D'ALIMENTATION, DU CÂBLAGE DE SIGNALISATION À LA BATTERIE ET DU TUYAU D'ARRIVÉE D'EAU

15

Connecter le câblage d'alimentation, le câblage de signalisation et le tuyau d'entrée d'eau au refroidisseur.

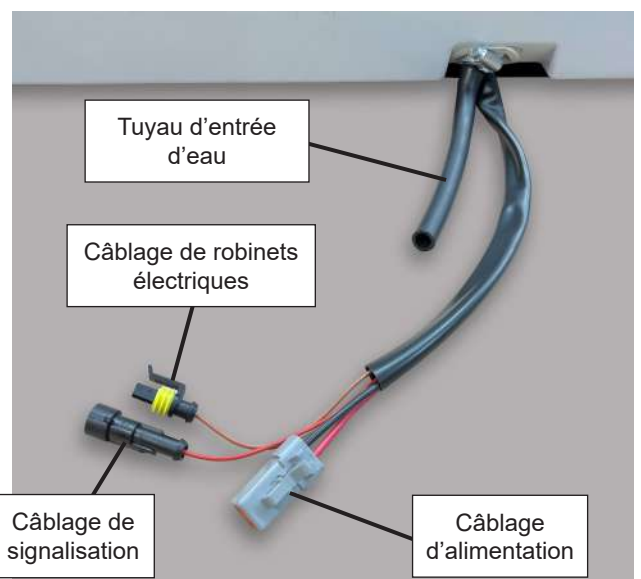
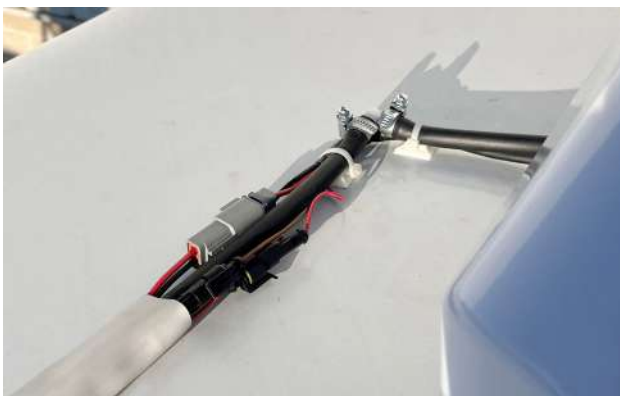

**16**

L'installateur décidera de la meilleure façon d'acheminer le câblage vers la batterie et le tuyau d'entrée d'eau vers le réservoir du véhicule.

**17**

**EVER** dispose d'un cache-tube pour protéger l'accès au câblage et au tuyau d'arrivée d'eau depuis le toit jusqu'à l'intérieur du véhicule.

Une fois installé, sceller avec de la silicone ou un produit similaire pour empêcher l'eau de pénétrer à l'intérieur du véhicule.

**18**

Raccorder le tuyau d'arrivée d'eau du refroidisseur au réservoir d'eau du véhicule.

19

Si le véhicule est équipé de robinets électriques, l'installateur fournira et installera le câblage nécessaire à l'activation des robinets électriques ou de la pompe à eau, en le raccordant au connecteur prévu à cet effet, situé à la sortie du refroidisseur.

Ce raccord fournit (-) 12V (négatif).

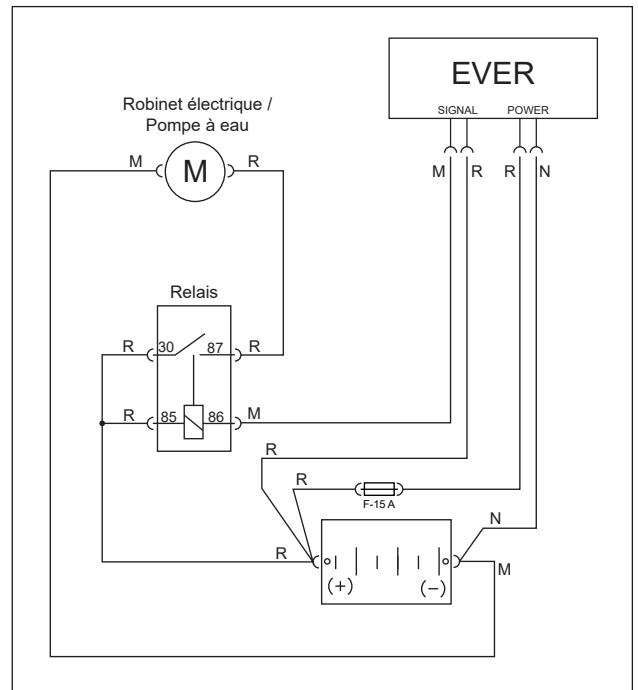

20

Connecter le câblage d'alimentation (positif et négatif) à la batterie. Connecter le câblage au positif de la batterie.

**Important :** Pour un fonctionnement correct de l'appareil, le câblage d'alimentation doit être connecté directement à la batterie.

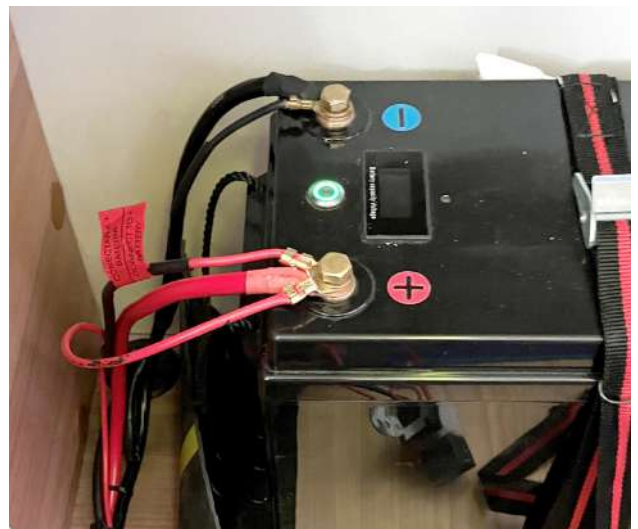

**Important :** Avant de mettre l'unité en marche, consultez le manuel de l'utilisateur, référence : 1003652994, disponible à l'adresse [www.bergstromspain.com](http://www.bergstromspain.com) pour établir une configuration correcte de l'appareil.



**SCHÉMA ÉLECTRIQUE**

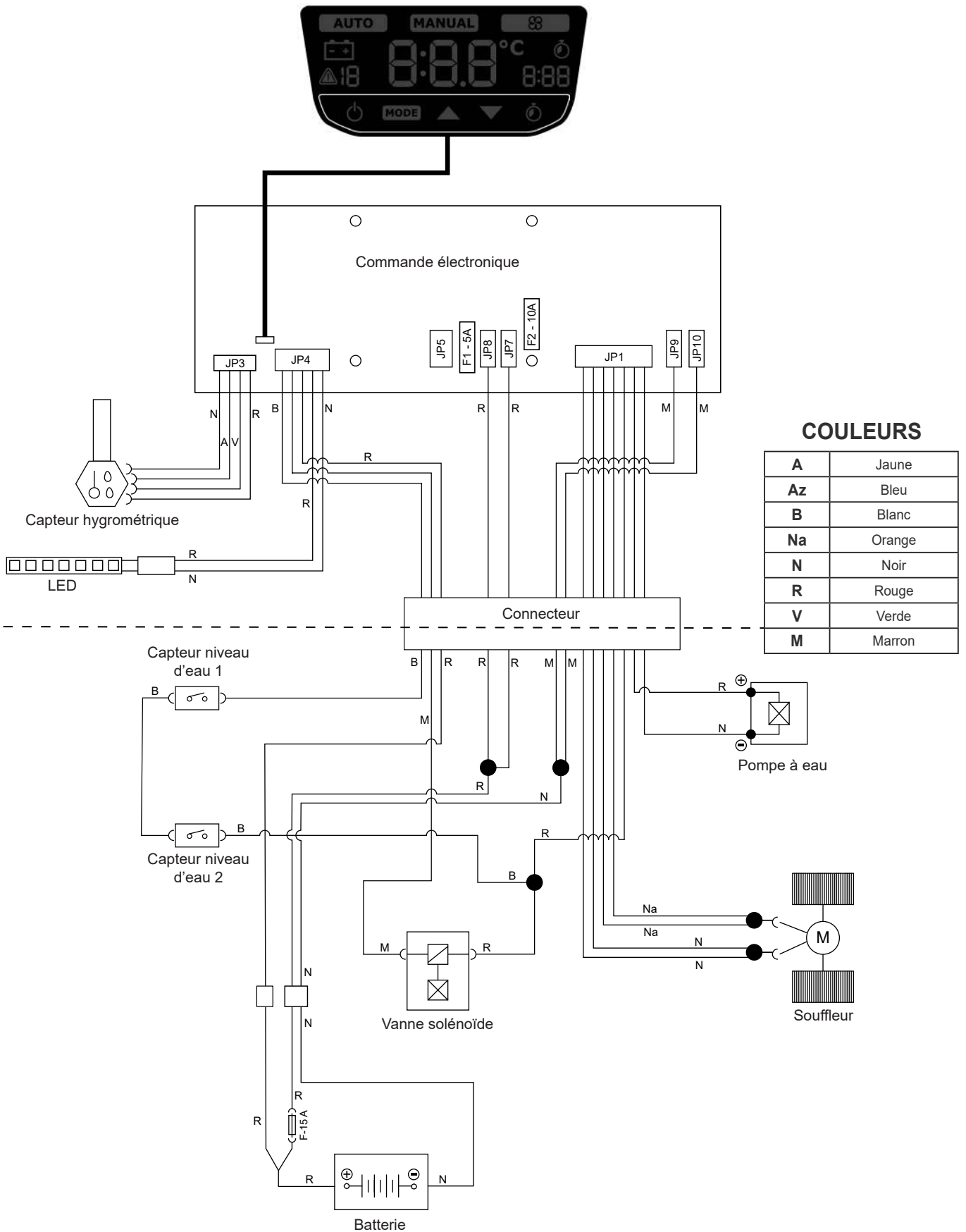



Wir danken Ihnen für Ihren Einkauf und Ihr Vertrauen in die Produkte unserer Caravaning-Reihe. **EVER** ist ein leistungsstarkes Öko-Dachkühlgerät von **Bergstrom** für den Einsatz in Wohnmobilen und anderen Freizeitfahrzeugen bei stehendem oder laufendem Motor. **EVER** ist die beste Wahl, um Haustiere sicher und kühl zu halten.

**EVER** wurde mit der fortschrittlichsten Technik konstruiert, um eine effiziente Leistung, eine Reduzierung des Kraftstoffverbrauchs und der CO<sub>2</sub>-Emissionen in die Atmosphäre zu erreichen. Durch diese Eigenschaften ist dieses Gerät einzigartig auf dem Markt der Kühlgeräte für Freizeitfahrzeuge.



**Bitte lesen Sie dieses Dokument vor der Installation des Produkts sorgfältig durch** und bewahren Sie es für den späteren Gebrauch auf. Die Originaldokumentation wurde in spanischer Sprache verfasst; bei allen anderen Sprachen handelt es sich um Übersetzungen.

Alle Produkthanleitungen sind in digitaler Form (PDF) unter <https://www.bergstromspain.com/> abrufbar.

Für alle Verkäufe und Garantievorgänge gelten unsere allgemeinen Geschäftsbedingungen in ihrer jeweils aktuellen Fassung, die auf unserer Website <https://www.bergstromspain.com/> veröffentlicht sind.

Diese Bedienungsanleitung entspricht den neuesten technischen Entwicklungen in diesem Bereich zum Zeitpunkt der Veröffentlichung. Aufgrund der kontinuierlichen Verbesserung kann es jedoch Abweichungen geben.

### Verwendete Symbole



- **Achtung:** Sicherheitshinweis, der auf eine Situation hinweist, die, wenn sie nicht vermieden wird, zum Tod oder zu schweren Verletzungen führen kann.



- **Gefahr:** Schnittgefahr. Weist auf eine Situation hin, die zu Schnittverletzungen führen kann.



- **Gefahr:** Stromschlaggefahr. Weist auf eine Situation hin, die zu einem Stromschlag führen kann.



- **Hinweis:** Sicherheitshinweis, der auf eine Situation hinweist, die, wenn sie nicht vermieden wird, zu Schäden am Gerät oder anderen Gegenständen führen kann.



- **Information:** Zusatzinformationen zu Installation oder Handhabung des Produkts.



- **Zerbrechlich:** Weist auf eine Situation hin, in der Vorsicht geboten ist, um Schäden am Gerät und anderen Gegenständen zu vermeiden.



### Haftung

- **Dirna Bergstrom** lehnt in den folgenden Fällen jede Haftung für Schäden ab:

- Beschädigung des Produkts durch mechanische Einflüsse und Überspannung.
- Änderungen am Gerät, die ohne ausdrückliche Genehmigung des Herstellers vorgenommen wurden.
- Verwendung des Geräts für Zwecke, die nicht in diesem Dokument beschrieben sind.
- Unsachgemäße Handhabung oder Installation des Kühlgeräts.

- Bei der Installation von **EVER** an dem Dach ist zu berücksichtigen, dass die Konstruktion von mit einer Luke ausgestatteten Fahrzeugen normalerweise ausreicht, um das Gewicht des Geräts zu tragen. Wenn dies jedoch nicht der Fall ist und das Dach aufgeschnitten werden muss, oder das Material (Glasfaser-, Kunststoffdächer usw.), trotz einer vorhandenen Dachluke nicht widerstandsfähig genug ist, **muss der Installateur unter seiner Verantwortung entscheiden**, ob zur Vermeidung möglicher Verformungen, Brüche, Eindringen von Wasser usw. eine Verstärkung erforderlich ist, und die hierfür erforderlichen Maßnahmen ergreifen.

**EVER** ist ein vielseitiges Kühlgerät, das auch in einem Winkel von 180° installiert werden kann, um es an den verfügbaren Platz auf dem Fahrzeugdach anzupassen, sodass es das übrige Zubehör nicht beeinträchtigt.



### Warnhinweise hinsichtlich der Montage

- Einbau, Reparatur und Wartung dieses Geräts dürfen nur von Fachpersonal durchgeführt werden, das in Bezug auf Fahrzeugklimatisierung, mögliche Gefahren und geltende Normen ausreichend geschult ist.
- Bitte lesen Sie die Installationsanleitung sorgfältig durch, bevor Sie mit der Installation des Kühlgeräts beginnen. Befolgen Sie bei der Installation genau die hier gegebenen

Anweisungen.

- Vor Installation des Kühlgeräts den Zündschlüssel abziehen.
- Vor Installation des Kühlgeräts die Fahrzeugbatterie abklemmen.
- Das Kühlgerät EVER sicher anbringen, damit es nicht herunterfallen kann.
- Für jeden Arbeitsschritt geeignete Werkzeuge benutzen.
- Bei der Installation auf den Anschluss der elektrischen Komponenten achten und prüfen, ob diese richtig sitzen.
- Wenn die Kabel bei der Installation entlang scharfkantiger Wände verlaufen, Leerrohre oder Führungen benutzen, um eine Beschädigung der Kabel zu vermeiden.



- **Wichtiger Hinweis:** Beim Anschluss des Kühlgeräts darauf achten, dass die Polarität nicht vertauscht wird. Ist dies der Fall, schaltet sich die Steuerung nicht ein und das Gerät geht nicht in Betrieb.
- Nach Installation des Kühlgeräts sind dem Benutzer die Winterabdeckungen und die Kurzanleitung des Produkts auszuhändigen.





### Für die Montage erforderliche Werkzeuge

- Torx-Kreuzschraubendreher 10
- Flachsraubendreher
- Schraubenschlüssel 10
- Bandmaß
- Stichsäge
- Cutter



### Bestimmungsgemäße Verwendung

- **EVER** ist ein leistungsstarkes Öko-Dachkühlgerät für den Einsatz in Wohnmobilen und anderen Freizeitfahrzeugen. Es eignet sich nicht für den Einbau und Betrieb in landwirtschaftlichen Maschinen oder Baumaschinen, bei denen starke Schwingungen auftreten.
- Um einen korrekten Betrieb des Geräts zu gewährleisten, sollte sich das Fahrzeug in horizontaler Position befinden. Sollte dies nicht möglich sein, bringen Sie die Vorderseite des Kühlgeräts in die höhere Position. Erscheint die Meldung   auf dem Display, wird der Modus AUTO oder MANUELL wieder aktiviert,

sobald das Fahrzeug besser nivelliert ist.

- Bei nicht bestimmungsgemäßer Verwendung erlischt die Garantie für das Kühlgerät und die Haftung des Herstellers ist ausgeschlossen.
- Wenn Sie hinsichtlich der Verwendung des Kühlgerätes **EVER** unsicher sind, schlagen Sie bitte in der Bedienungsanleitung des Produkts nach.



### Zugehörige Dokumente

- Kurzanleitung: 1003653001
- Bedienungsanleitung: 1003652994
- Ersatzteilliste: 1003652997
- Fehlerbehebung: 1003652996

In Übereinstimmung mit der internationalen Qualitätsmanagementnorm ISO 9001, Qualitätsmanagement in der Automobilindustrie IATF 16949 und Umweltmanagementnorm ISO 14001 wendet Dirna Bergstrom Qualitätssicherungsprozesse an, um die höchste Qualität seiner Produkte zu gewährleisten. Zertifiziert durch das IQNet Quality System.

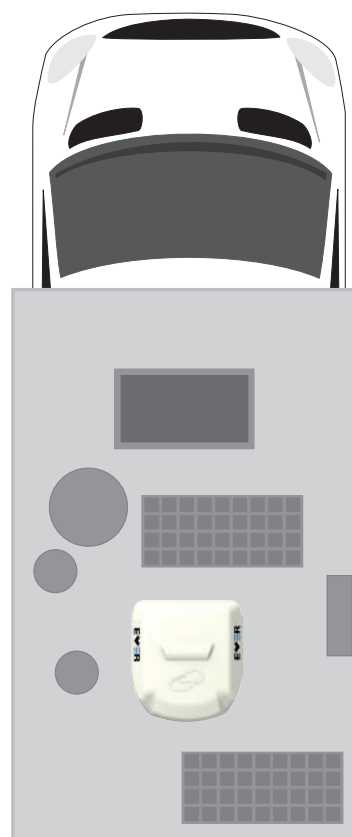
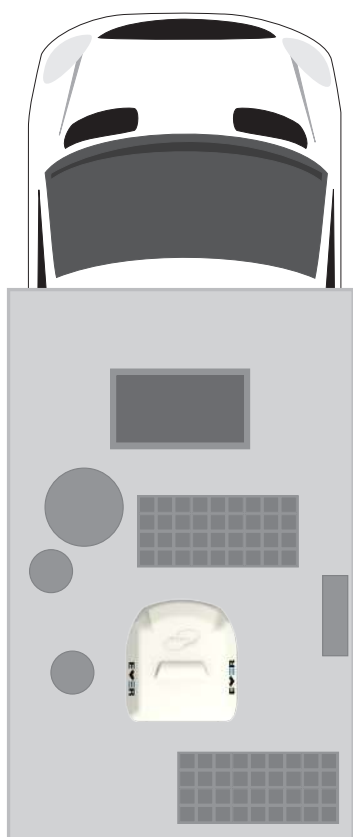

**MONTAGEMÖGLICHKEITEN**

**Achtung:** Um eine gute Belüftung des Geräts zu gewährleisten und Fehlfunktionen zu vermeiden, muss um das Gerät herum ein Freiraum von mindestens 10 cm vorhanden sein.

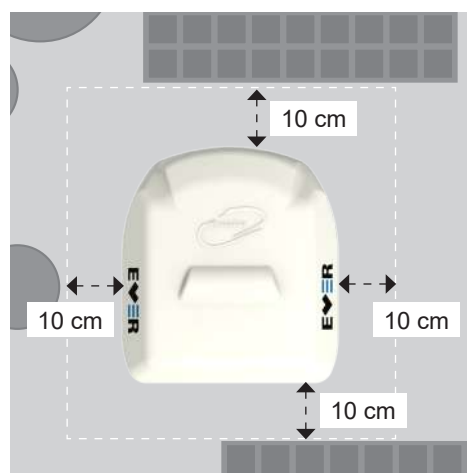

# VORBEREITENDE TÄTIGKEITEN FÜR DEN EINBAU DES KÜHLGERÄTS IN FAHRZEUGEN OHNE DACHLUKE

**1** Legen Sie die im Lieferumfang des **EVER**-Geräts enthaltene Schnittvorlage auf das Fahrzeugdach und markieren Sie die korrekte Einbauposition für das Kühlgerät.

**Achtung:** Stellen Sie sicher, dass die außen angebrachte Markierung bei Montage des Innengeräts zu keiner Behinderung von Elementen im Fahrzeuginnenraum führt.

**Hinweis:** **EVER** ist ein vielseitiges Kühlgerät, das auch in einem Winkel von 180° installiert werden kann, um es an den verfügbaren Platz auf dem Fahrzeugdach anzupassen, sodass es das übrige Zubehör nicht beeinträchtigt.



**2** Markieren Sie von außen den 400 x 400 mm großen Bereich, in dem sich das Kühlgerät befinden wird. Bohren Sie je (1) Loch in die 4 Ecken des markierten Bereichs.

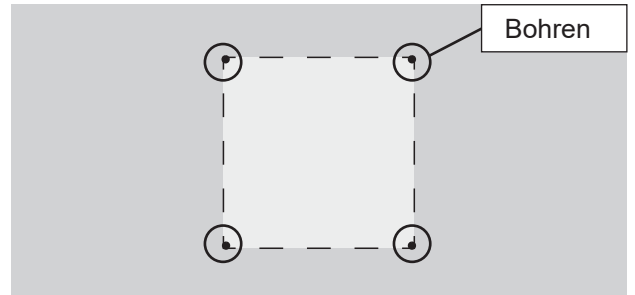

**3** Schneiden Sie das durch die Löcher markierte Quadrat im Dach von der Außenseite des Fahrzeugs mit einer Stichsäge aus. Schneiden Sie in dem Bereich nun von innen die Füllung und die Zwischendecke durch.

**Achtung:** Achten Sie beim Schneiden auf möglicherweise vorhandene Kabelführungen.





## ANFORDERUNGEN FÜR DEN EINBAU DES KÜHLGERÄTS IN FAHRZEUGEN MIT DACHLUKE



**Achtung: EVER** kann nur in Fahrzeuge mit Dachluke eingebaut werden, die folgende Voraussetzungen erfüllen:

- Deckenöffnung 400 x 400 mm
- Deckenstärke 30 bis 60 mm

**4**

Luke und Rahmen aus dem Fahrzeug ausbauen, in das das Kühlgerät **EVER** eingebaut werden soll.



## INSTALLATION DES KÜHLGERÄTS EVER

**5**

Die EPDM-Montagedichtung um die Lukenöffnung bzw. den ausgeschnittenen Bereich anbringen.





**WIE DIE EPDM-DICHTUNG GESCHNITTEN A WIRD, UM WASSERUNDICHTIGKEITEN IN DIE KABINE ZU VERMEIDEN**

- A- Dichtung aufkleben und dabei einen Papierschutz von 100 mm auf jeder Seite beibehalten.
- B- Die zwei Papierstücke entfernen.
- C- Unter Anpressen beider Enden aufkleben.

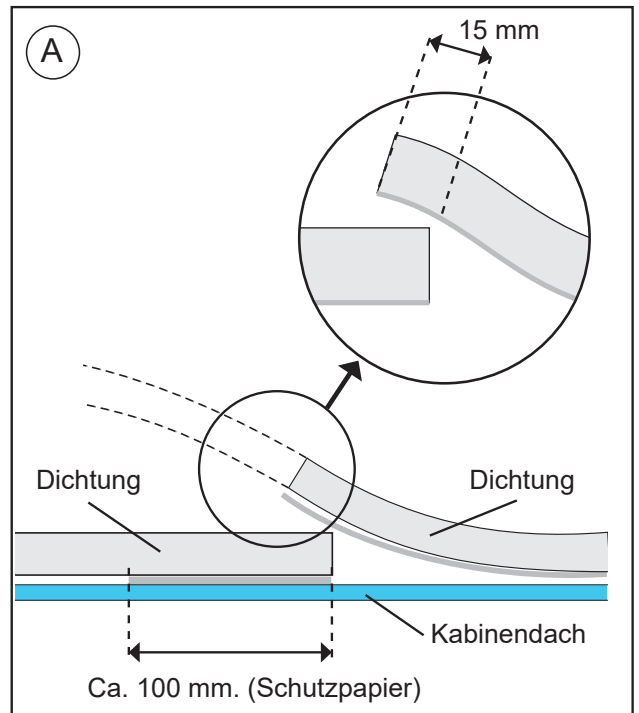
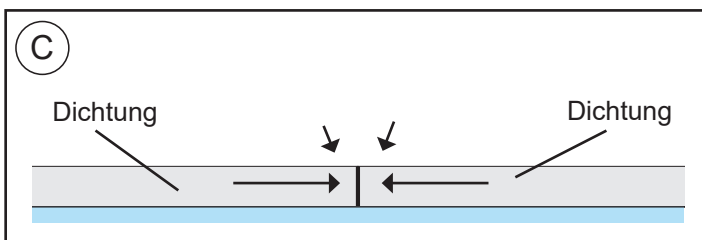
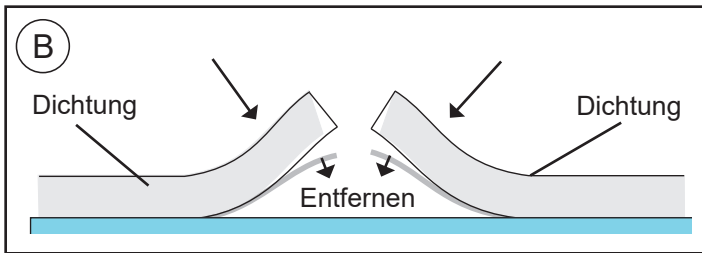

**6**

Das Kühlgerät auf die Montagedichtung legen und vom Fahrzeuginneren aus in Bezug auf die Dachöffnung zentrieren. Dabei darauf achten, dass die (4) Befestigungspunkte der Sockelhalterungen des Kühlgeräts in der Deckenöffnung zentriert sind.



**7**

(4) Stiftschrauben 60 mm in den Befestigungspunkten des Kühlgerätesockels einsetzen.



**8**

Die (4) Stiftschrauben mit je (1) Breitflansch-Flachscheibe, (1) Federring und (1) Mutter an der Geräteunterseite anbringen.

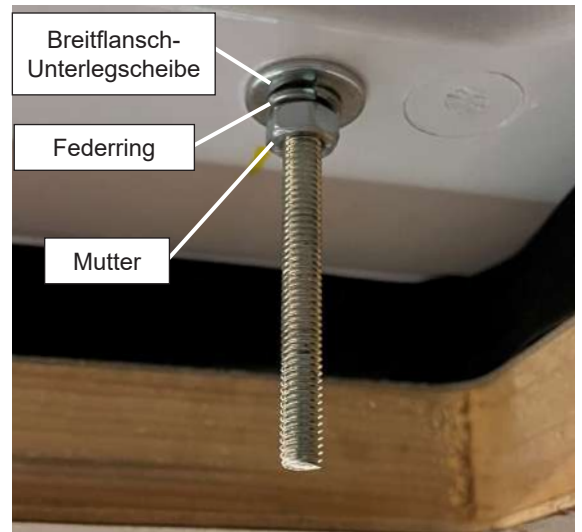

**9**

Auf jeder Stiftschraube (1) Mutter und (1) Breitflansch-Flachscheibe mit folgenden ungefähren Abständen zum Gerätesockel anbringen:

- 30 mm Dicke: 11 bis 14 mm (\*)
- 40 mm Dicke: 21 bis 24 mm
- 50 mm Dicke: 31 bis 34 mm
- 60 mm Dicke: 41 bis 44 mm

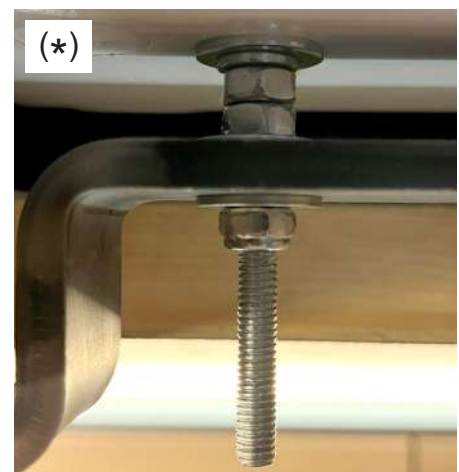
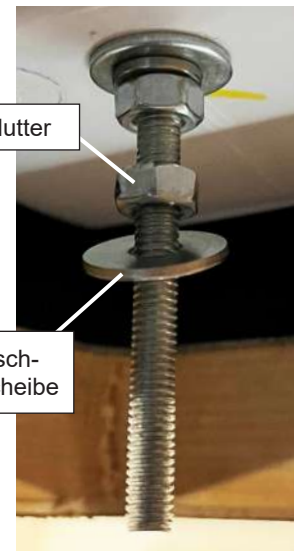
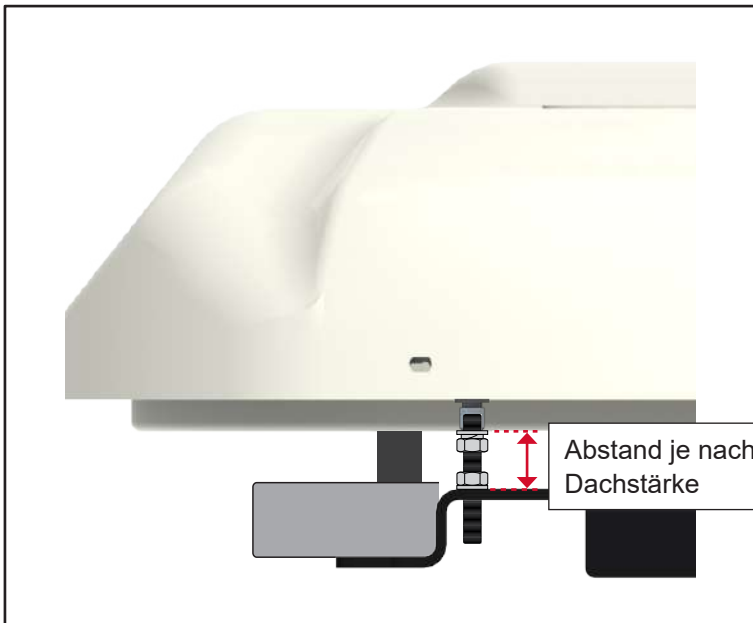

Endmontage der Befestigungshalterung an einem 30 mm dicken Dach

10

Die Befestigungshalterungen an den Stiftschrauben der Geräteunterseite anbringen und mit je (1) Breitflansch-Flachscheibe und (1) selbstsichernder Mutter fixieren.

**Achtung:** Die Befestigungshalterungen müssen in der gezeigten Position montiert werden.



Breitflansch-Unterlegscheibe

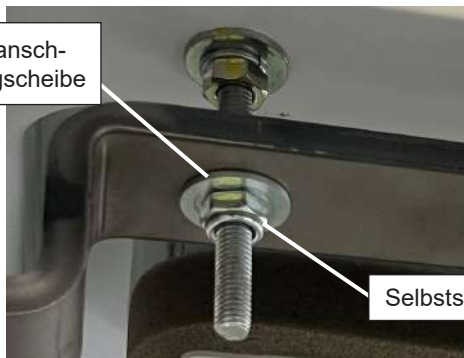

Selbstsichernde Mutter

11

Die selbstsichernden Muttern der Befestigungshalterungen anziehen und dabei die äußere EPDM-Dichtung des Dachs um 3 bis 6 mm zusammendrücken.

**Wichtiger Hinweis:** Um ein eventuelles Eindringen von Wasser in das Kabineninnere zu vermeiden, muss sichergestellt sein, dass die EPDM-Dichtung wie im Montageplan (S. 52) gezeigt vom Gerätesockel zusammengedrückt wird.



Selbstsichernde Mutter

12

Die (4) oberen Muttern der Halterungen fest anziehen.

**Wichtiger Hinweis:** Wenn die Halterungen richtig angezogen sind, sollten sie flach am Dach anliegen. Ist dies nicht der Fall, kann es beim Einbau des Innengeräts zu Schwierigkeiten kommen.

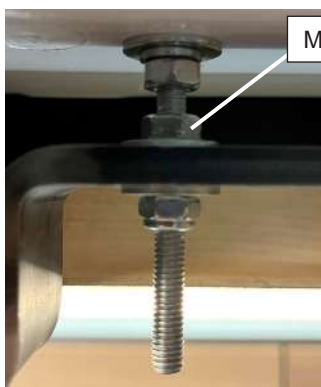

Mutter anziehen

**MONTAGEPLAN**

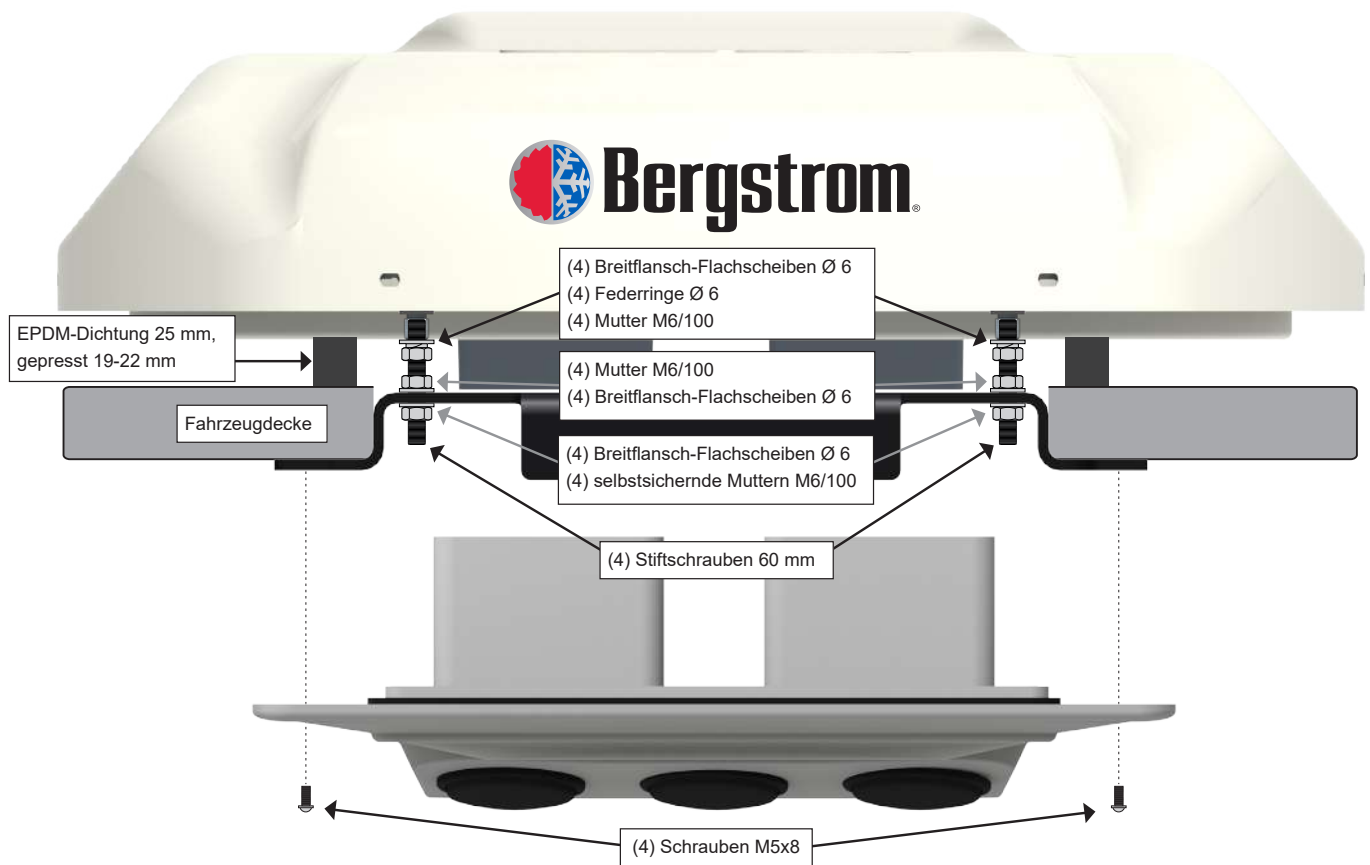

**13**

Kabel des Innengeräts an die Gerätekabel anschließen.

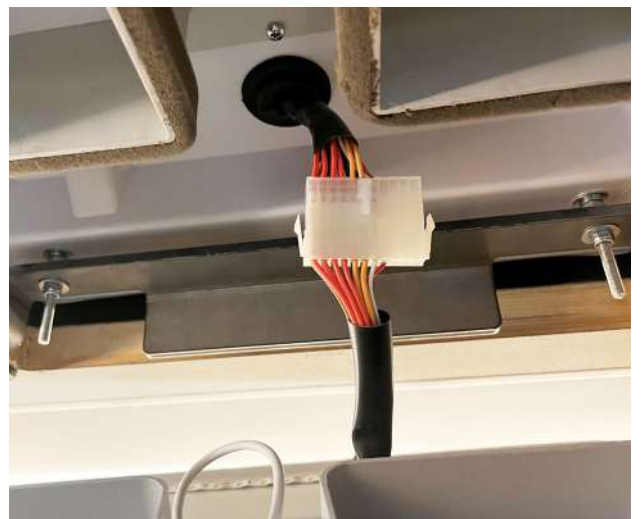



14

Innengerät mit (4) Schrauben M5x8 montieren.



## MONTAGE VON STROMKABEL, SIGNALKABEL ZUR BATTERIE UND WASSERZULEITUNG

15

Stromkabel, Signalkabel und Wasserzuleitung zum Kühlgerät anschließen.

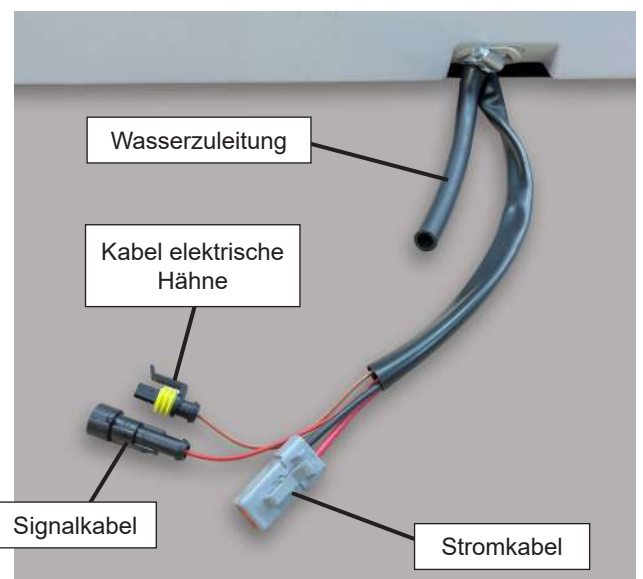



**16**

Der Installateur entscheidet über die beste Führung der Kabel zur Batterie und der Wasserzuleitung zum Wassertank des Fahrzeugs.

**17**

**EVER** verfügt über eine Leitungsabdeckung, um den Zugang zur Verkabelung und zur Wasserleitung vom Dach in den Innenraum des Fahrzeugs zu schützen.

Diese muss nach dem Einbau mit Silikon oder ähnlichem abgedichtet werden, um zu verhindern, dass Wasser in das Fahrzeuginnere eindringt.

**18**

Wasserzuleitung des Kühlers mit dem Wassertank des Fahrzeugs verbinden.

19

Ist das Fahrzeug mit elektrischen Wasserhähnen ausgestattet, muss der Installateur die Aktivierungskabel der elektrischen Hähne oder der Wasserpumpe liefern und installieren, indem er sie an den dafür vorgesehenen Anschluss am Kühlgeräteausgang anschließt.

Dieser Anschluss liefert (-)12V (negativ).

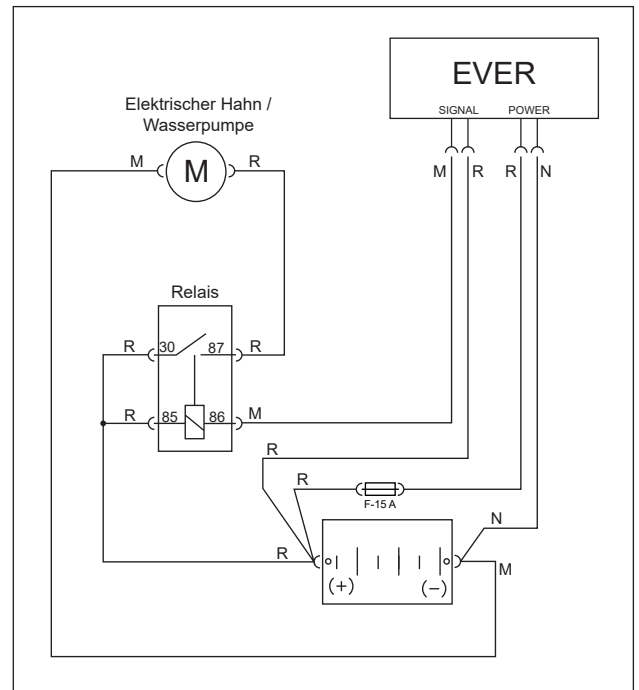

20

Stromkabel (positiv und negativ) an die Batterie anschließen. Signalkabel an den Pluspol der Batterie anschließen.

**Wichtiger Hinweis:** Für den ordnungsgemäßen Betrieb des Geräts muss das Stromkabel direkt an die Batterie angeschlossen werden.

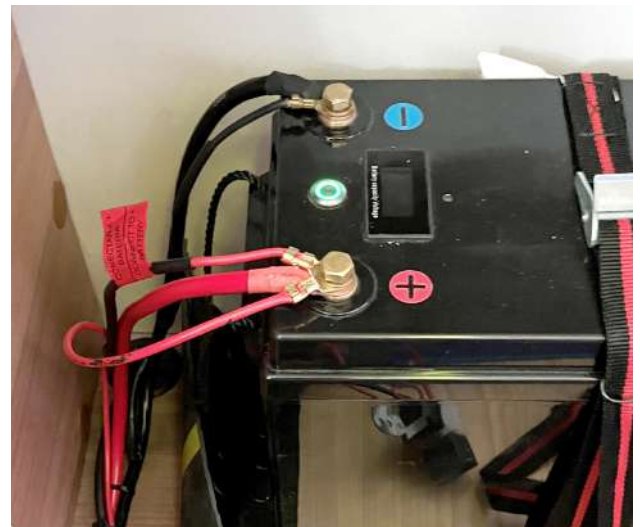

**Wichtiger Hinweis:** Bevor Sie das Gerät in Betrieb nehmen, lesen Sie bitte die Bedienungsanleitung (Referenz 1003652994), die Sie unter [www.bergstromspain.com](http://www.bergstromspain.com) finden können, um das Gerät richtig zu konfigurieren.

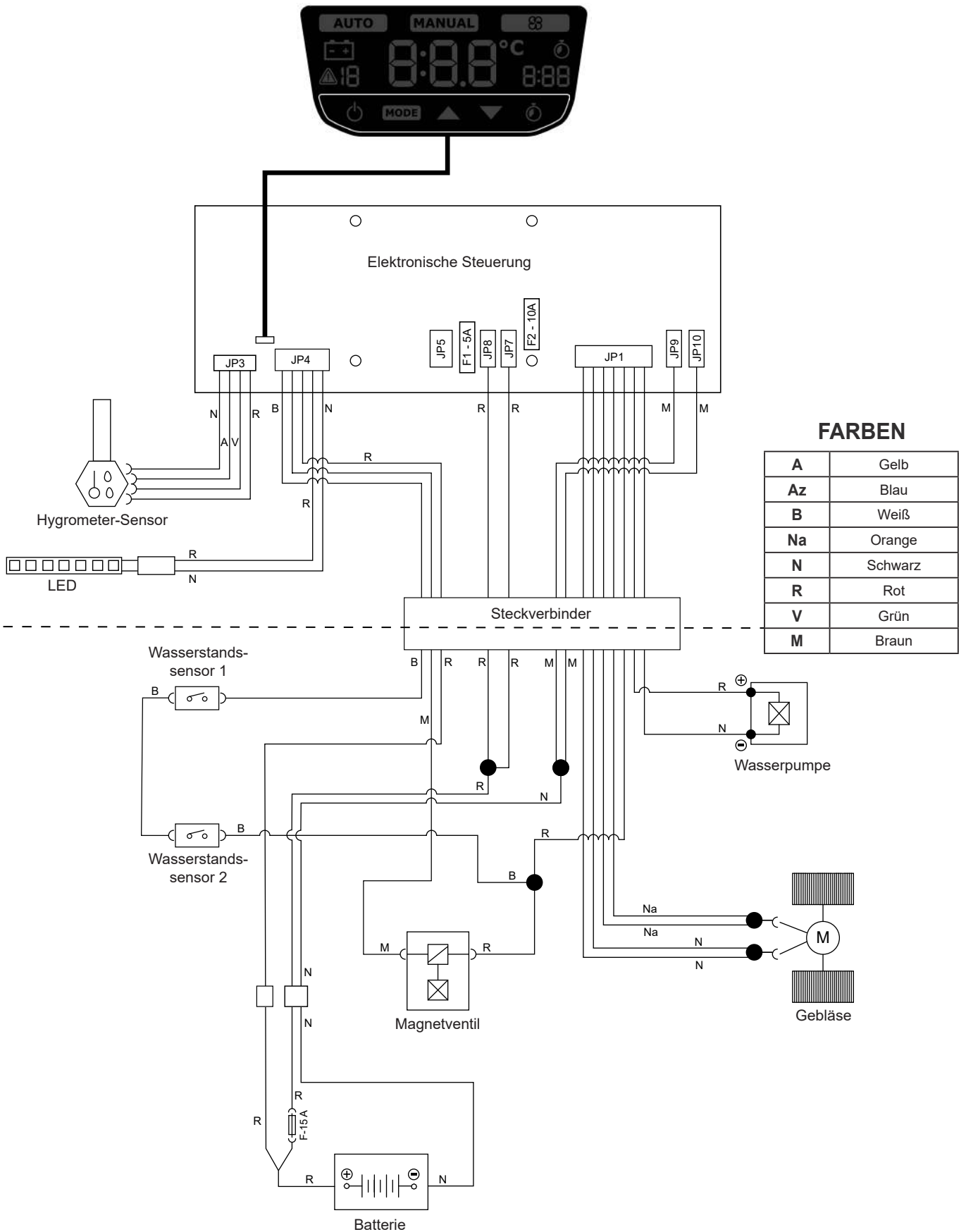



Grazie per l'acquisto e per la fiducia riposta nella nostra gamma di prodotti Caravanning. **EVER** è un raffrescatore ecologico altamente performante, prodotto da **Bergstrom**, da installare sul tettuccio di camper e altri veicoli ricreazionali e da usare con il motore fermo o in moto. **EVER** è la scelta giusta per mantenere gli animali domestici al sicuro e al fresco.

**EVER** è progettato con la tecnologia più avanzata per garantire prestazioni efficienti, ridurre il consumo di carburante e le emissioni di CO<sub>2</sub> in atmosfera. Queste caratteristiche lo rendono unico nel mercato del raffrescamento dei veicoli ricreazionali.



**Leggere attentamente questo documento prima di installare il prodotto.**

Conservare questo documento con cura per poterlo consultare in futuro. La documentazione originale è stata stilata in spagnolo, perciò le altre lingue sono traduzioni.

Tutti i manuali del prodotto sono disponibili in versione digitale (PDF) su <https://www.bergstromspain.com/>

La vendita e la garanzia sono disciplinate dalla versione più aggiornata delle nostre condizioni generali di vendita, pubblicata sul nostro sito web <https://www.bergstromspain.com/>

Questo manuale è aggiornato riguardo agli sviluppi tecnici più avanzati di questa gamma al momento della pubblicazione. Tuttavia, potrebbero riscontrarsi differenze dovute al continuo miglioramento.

**Spiegazione dei simboli**



- **Avvertenza:** Avvertenza di sicurezza riguardo a una situazione che, se non venisse evitata, potrebbe provocare gravi lesioni anche mortali.



- **Pericolo:** Rischio di taglio. Segnala una situazione che potrebbe provocare una lesione da taglio.



- **Pericolo:** Rischio di folgorazione. Segnala una situazione che potrebbe provocare una lesione da folgorazione.



- **Avviso:** Avviso di sicurezza riguardo a una situazione che, se non venisse evitata, potrebbe provocare danni all'impianto o ad altri materiali.



- **Informazioni:** Ulteriori informazioni sull'installazione o sulla gestione del prodotto.



- **Fragile:** Indica una situazione in cui si deve procedere con attenzione per non causare danni all'impianto e ad altri materiali.



**Esclusione di responsabilità**

- **Dirna Bergstrom** declina ogni responsabilità per danni nei seguenti casi:

- Danni al prodotto provocati da sollecitazioni meccaniche e sovratensioni.
  - Modifiche effettuate sull'impianto senza esplicita autorizzazione del costruttore.
  - Uso dell'impianto per fini diversi da quelli riportati in questo documento.
  - Movimentazione o installazione errata del raffrescatore.
- Quando si installa **EVER** sul tettuccio, si deve tenere conto del fatto che normalmente i veicoli dotati di oblò hanno una struttura sufficiente a sostenere il peso dell'impianto. Tuttavia, quando ciò non avviene ed è necessario praticare un taglio nel tettuccio o quando, pur essendo presente l'oblò, il materiale non è abbastanza resistente (tettuccio in fibra, plastica, ecc.), **l'installatore deve decidere, sotto la propria responsabilità**, la necessità di rinforzarlo per evitare eventuali deformazioni, rotture, infiltrazioni d'acqua, ecc.

**EVER** è un raffrescatore versatile che può essere montato ruotato di 180° per adattarlo allo spazio disponibile sul tettuccio del veicolo in modo tale da non interferire con altri accessori.



**Avvertenze durante il montaggio**

- L'installazione, la riparazione e la manutenzione di questo impianto possono essere eseguite esclusivamente da personale tecnico in possesso della formazione necessaria nel campo dell'aria condizionata per veicoli, e al corrente degli eventuali pericoli e delle norme applicabili.
- Leggere attentamente le istruzioni di montaggio prima di iniziare l'installazione del raffrescatore. Durante l'installazione, seguire alla lettera le istruzioni indicate.
- Disinserire la chiave di avviamento prima di iniziare l'installazione del raffrescatore.
- Disinserire la batteria del veicolo prima di cominciare l'installazione del raffrescatore.
- Fissare saldamente **EVER** per evitare cadute.
- Usare gli attrezzi più adatti per ogni operazione.

- Durante l'installazione, assicurare la connessione dei componenti elettrici, verificandone il corretto inserimento.
- Se nell'installazione i cablaggi devono attraversare pareti con bordi aguzzi, proteggere adeguatamente i cavi con guaine o passacavi per evitarne il danneggiamento.



- **Avvertenza importante:** quando si collega il raffrescatore, fare attenzione a non invertire le polarità. Se ciò dovesse succedere, il quadro comandi non si accende e l'impianto non si avvia.
- Dopo l'installazione del raffrescatore, è necessario consegnare all'utente le coperture invernali e la guida rapida del prodotto.





### Attrezzi consigliati per il montaggio

- Cacciavite a croce Thorx 10
- Cacciavite a taglio
- Chiave aperta da 10 mm
- Metro a nastro
- Seghetto alternativo
- Taglierino



### Corretto uso del prodotto

- **EVER** è un raffrescatore ecologico altamente performante adatto all'installazione sul tettuccio di camper e di altri veicoli ricreazionali. Non è adatto a macchinari agricoli, né per l'edilizia soggetti a forti vibrazioni.
- Per garantire il corretto funzionamento dell'unità, si consiglia di mantenere il veicolo in posizione orizzontale oppure, se ciò non fosse possibile, di montare la parte anteriore del raffrescatore nella posizione più alta. Se sul display compare l'errore  , la modalità AUTO o MANUALE viene riattivata quando il veicolo è livellato.
- L'uso non conforme a quello previsto comporta l'annullamento della garanzia del raffrescatore e l'esclusione di responsabilità da parte del costruttore.
- In caso di incertezze riguardo all'uso di **EVER**, consultare il manuale dell'utente del prodotto.



### Documenti correlati

- Guida rapida: 1003653001
- Manuale dell'utente: 1003652994
- Elenco dei pezzi di ricambio: 1003652997
- Diagnosi dei guasti: 1003652996

In conformità con gli standard internazionali di gestione della qualità ISO 9001, di qualità automobilistica IATF 16949 e di gestione ambientale ISO 14001, **Dirna Bergstrom** applica processi volti ad assicurare l'eccellenza e garantire la massima qualità dei propri prodotti. Certificato dall'IQNet Quality System.

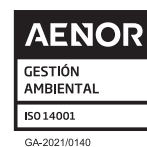

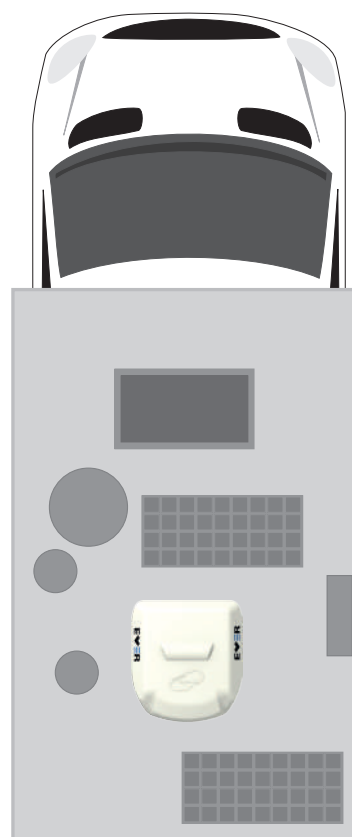
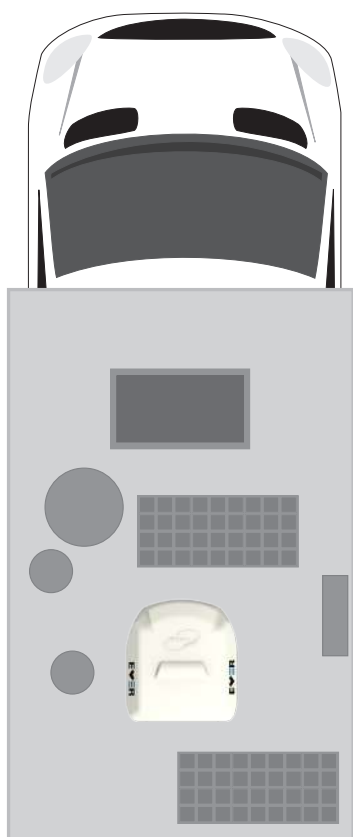

**OPZIONI DI MONTAGGIO**

**Attenzione:** per garantire la corretta ventilazione dell'apparecchio e per evitare malfunzionamenti, occorre lasciare uno spazio libero di almeno 10 cm intorno all'unità.

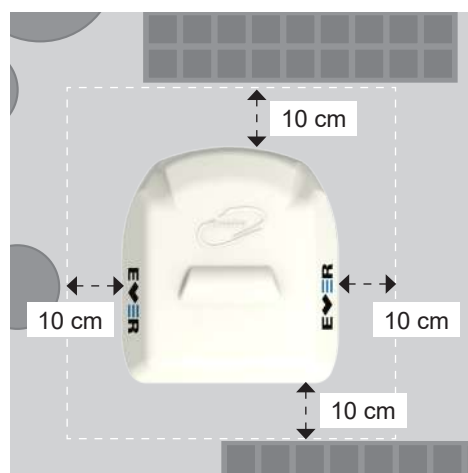

# OPERAZIONI PRELIMINARI ALL'INSTALLAZIONE DEL RAFFRESCATORE EVER SU VEICOLI SENZA OBLÒ SUL TETTuccio

**1** Prendere la dima che si trova nella scatola del raffrescatore **EVER** e posizionarla sul tettuccio del veicolo per segnare la posizione esatta in cui deve essere installato.

**Attenzione:** verificare che la posizione segnata all'esterno non interferisca con alcun elemento dell'abitacolo del veicolo nel montaggio della console interna del raffrescatore.

**Nota:** **EVER** è un raffrescatore versatile che può essere montato ruotato di 180° per adattarlo allo spazio disponibile sul tettuccio del veicolo in modo tale da non interferire con altri accessori installati.

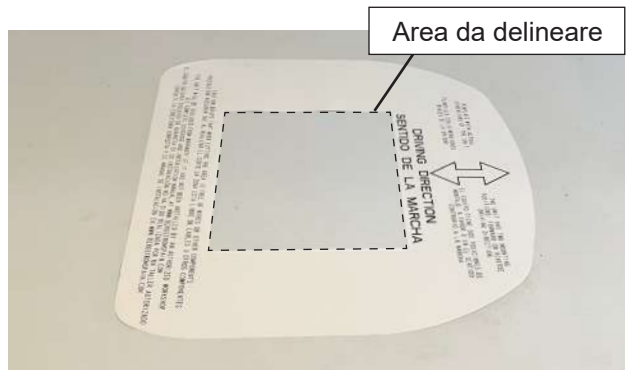

**2** Dall'esterno del veicolo, delineare l'area di 400 x 400 mm in cui verrà installato il raffrescatore. Praticare (1) foro in ciascuno dei 4 angoli dell'area delineata.

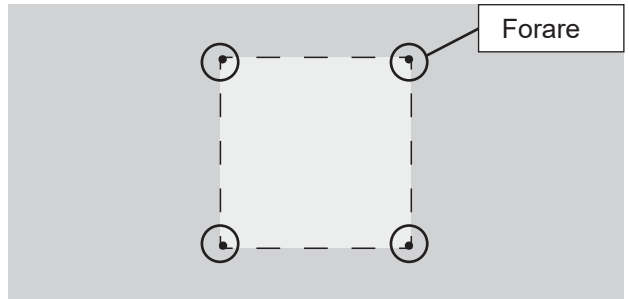

**3** Dall'esterno del veicolo, unire i fori tagliando il tettuccio con un seghetto alternativo. Completare il taglio dall'interno tagliando l'ovatta e il controsoffitto.

**Attenzione:** durante l'esecuzione del taglio è necessario prestare attenzione alla possibilità di incontrare un passaggio di cavi.



## REQUISITI PER L'INSTALLAZIONE DEL RAFFRESCATORE EVER IN VEICOLI CON OBLÒ SUL TETTuccio



**Attenzione:** **EVER** può essere installato solo su veicoli con oblò, aventi:

- Apertura sul tettuccio di 400 x 400 mm
- Spessore del tettuccio da 30 a 60 mm

**4**

Rimuovere l'oblò e il telaio del veicolo in cui deve essere installato il raffrescatore **EVER**.



## INSTALLAZIONE DEL RAFFRESCATORE EVER

**5**

Montare la guarnizione di montaggio in EPDM intorno all'apertura dell'oblò o al taglio eseguito.



Guarnizione EPDM



**COME TAGLIARE LA GUARNIZIONE EPDM A PER EVITARE L'INFILTRAZIONE DELL'ACQUA NELLA CABINA**

**A-** Incollare la guarnizione, lasciando 100 mm di carta protettiva su ogni lato.

**B-** Rimuovere i due pezzi di carta.

**C-** Incollare premendo entrambe le estremità.

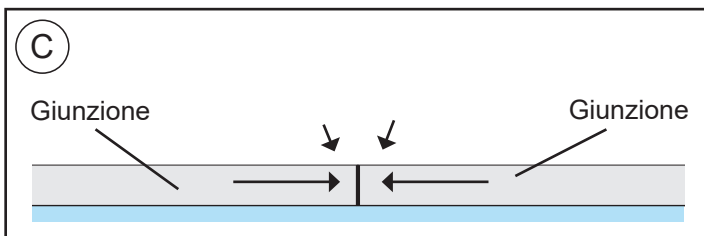
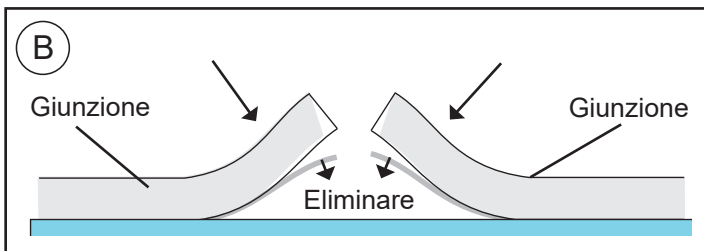
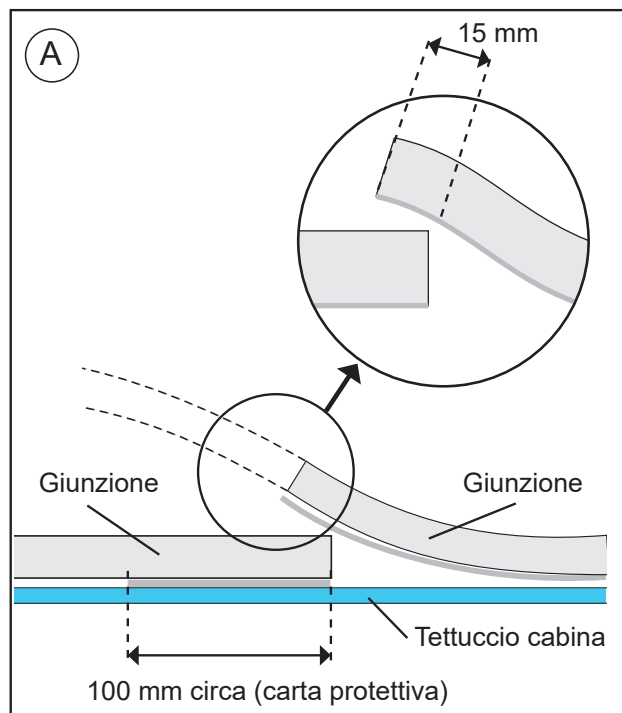

**6**

Posizionare il raffrescatore sulla guarnizione di montaggio centrandolo sull'apertura del tettuccio dall'interno del veicolo, assicurandosi che i (4) punti di fissaggio delle staffe di base del raffrescatore siano centrati nell'apertura del tettuccio.



**7**

Montare (4) viti prigioniere da 60 mm sui punti di fissaggio della base del raffrescatore.



**8**

Fissare le (4) viti prigioniere alla base dell'unità con (1) rondella a fascia larga, (1) rondella grower e (1) dado ciascuna.

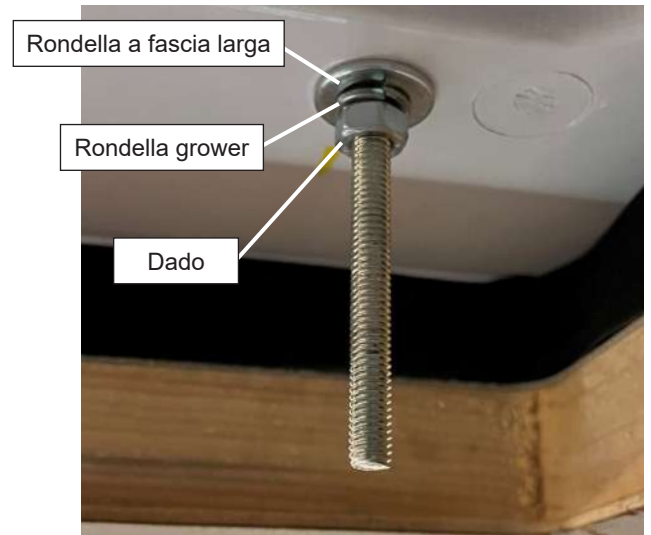

**9**

Montare (1) dado e (1) rondella a fascia larga su ciascuna vite prigioniera a una distanza approssimativa dalla base del raffrescatore:

- Spessore di 30 mm: tra 11 e 14 mm (\*)
- Spessore di 40 mm: tra 21 e 24 mm
- Spessore di 50 mm: tra 31 e 34 mm
- Spessore di 60 mm: tra 41 e 44 mm

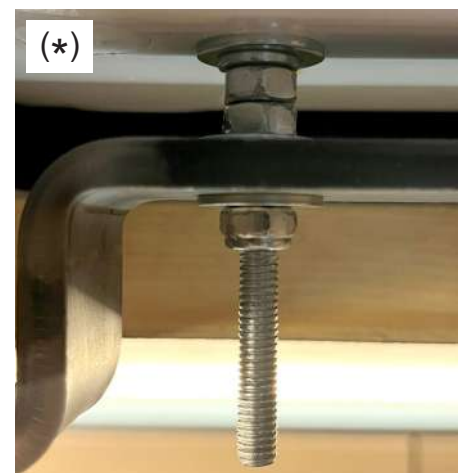
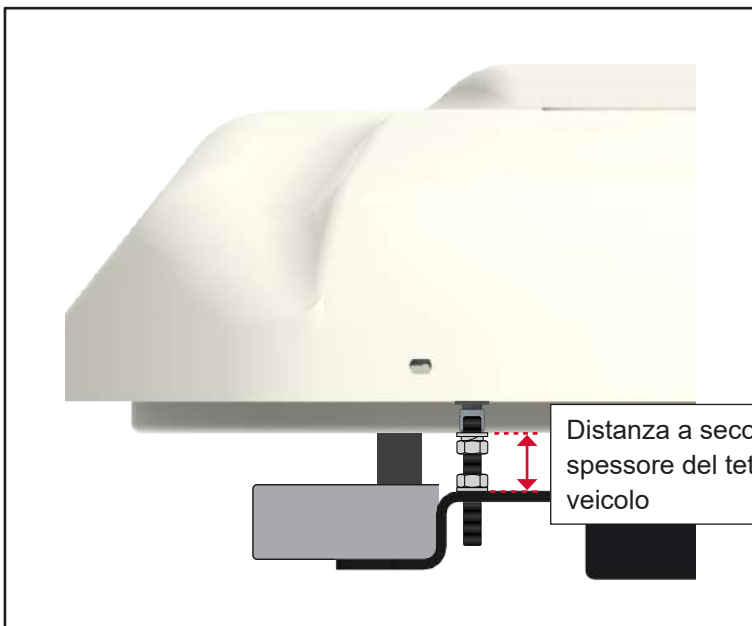
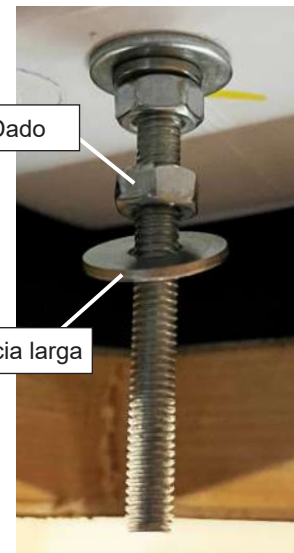

Dettaglio del montaggio finale della staffa di fissaggio sul tettuccio di 30 mm di spessore



10

Posizionare le staffe di fissaggio sulle viti prigioniere della base del raffrescatore e fissarle con (1) rondella a fascia larga e (1) dado autobloccante su ciascuna vite prigioniera.

**Attenzione:** le staffe di fissaggio devono essere montate nella posizione indicata.



Rondella a fascia larga



Dado autobloccante

11

Stringere i dadi autobloccanti delle staffe di fissaggio comprimendo la guarnizione esterna in EPDM del tettuccio di 3-6 mm.

**Nota bene:** per evitare eventuali perdite d'acqua all'interno dell'abitacolo, la guarnizione in EPDM deve essere premuta contro la base dell'unità come mostrato nello schema di montaggio (pag. 66).



Dado autobloccante

12

Stringere (4) dadi superiori delle staffe per completare il fissaggio delle stesse.

**Nota bene:** una volta strette correttamente, le staffe devono essere in piano rispetto al tettuccio. Altrimenti, potrebbero sorgere difficoltà nel montaggio della console interna.

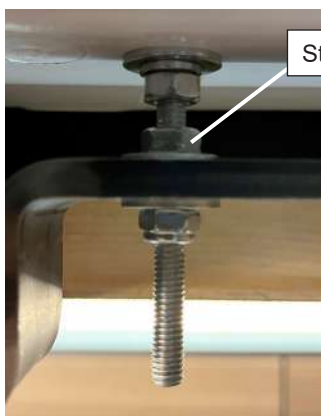

Stringere il dado



**SCHEMA DI MONTAGGIO**

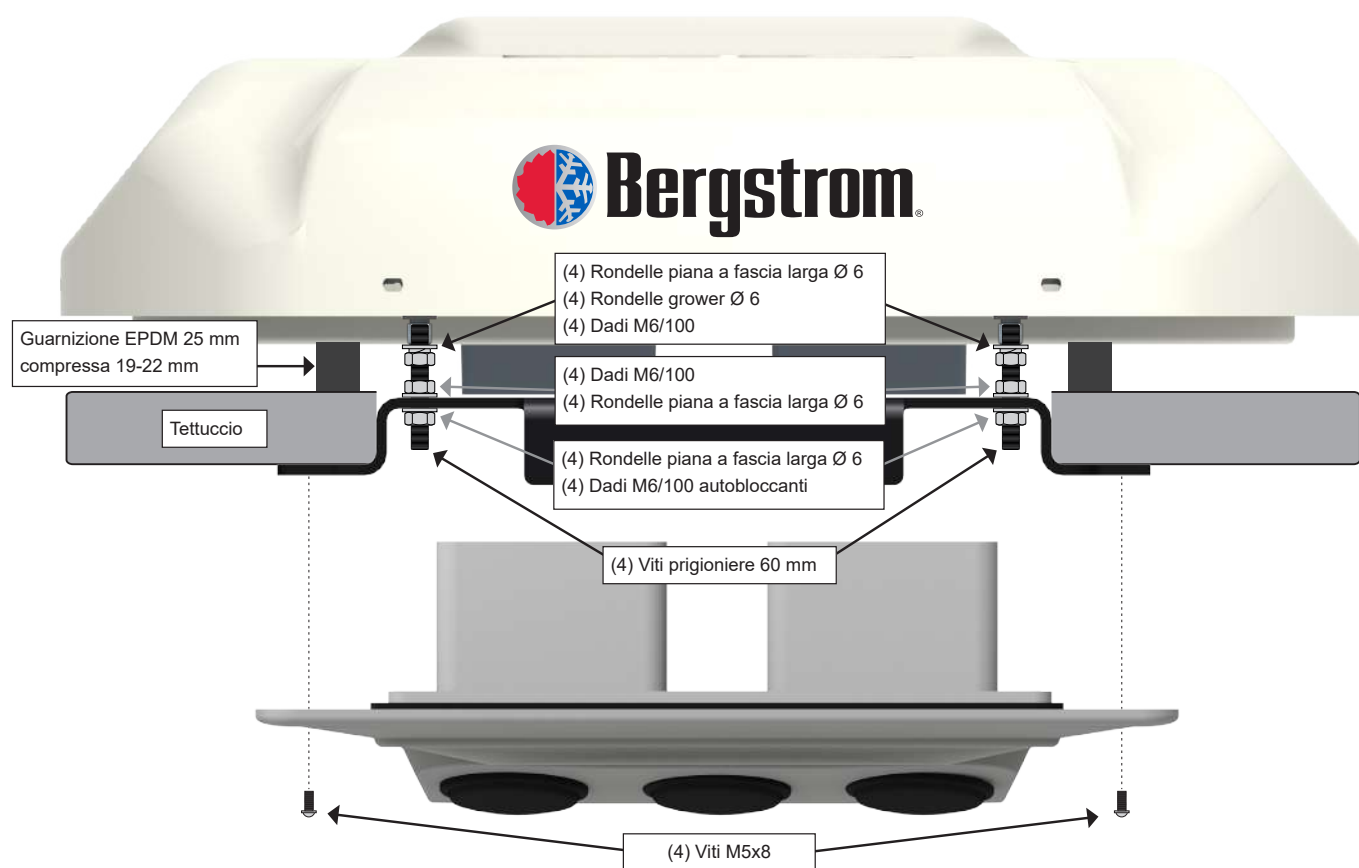

**13** Collegare il cablaggio dalla staffa interna al cablaggio del raffrescatore.

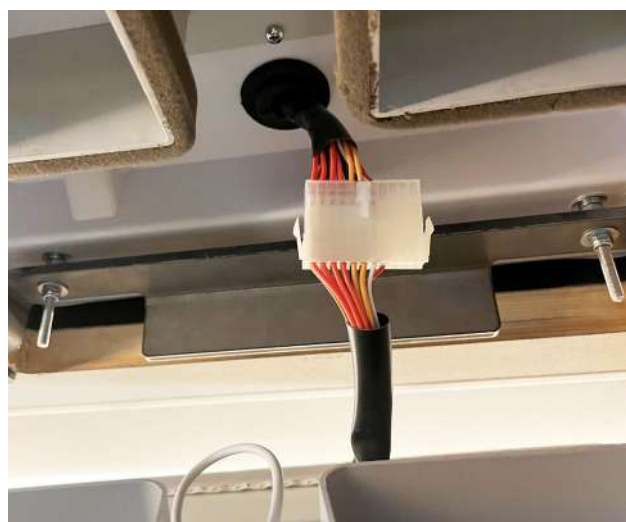

14

Montare la console interna con (4) viti M5x8.



**MONTAGGIO DEL CABLAGGIO DELL'ALIMENTAZIONE, DEL CABLAGGIO DEL SEGNALE ALLA BATTERIA E DEL TUBO DI ENTRATA DELL'ACQUA**

15

Collegare il cablaggio di alimentazione, il cablaggio del segnale e il tubo di entrata dell'acqua al raffrescatore.

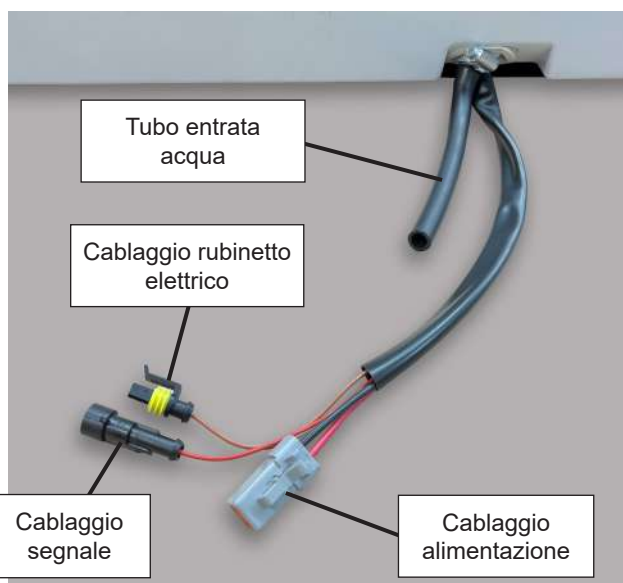
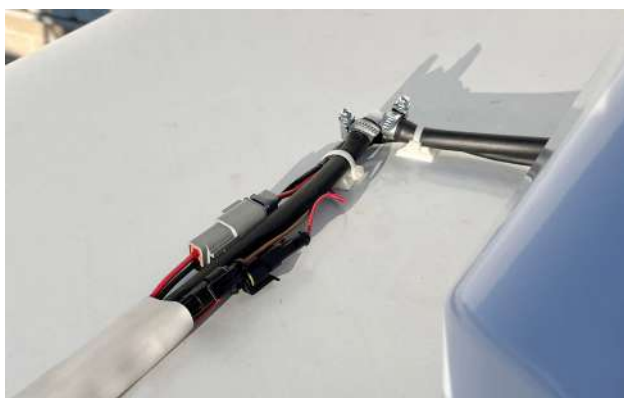

**16**

L'installatore deve decidere il percorso migliore per il cablaggio alla batteria e per il tubo di entrata dell'acqua al serbatoio del veicolo.

**17**

**EVER** è dotato di una copertura per proteggere l'accesso del cablaggio e del tubo dell'acqua dal tettuccio all'interno del veicolo.

Una volta installato, sigillare con silicone o simile per evitare che l'acqua penetri all'interno del veicolo.

**18**

Collegare il tubo di entrata dell'acqua dal raffrescatore al serbatoio dell'acqua del veicolo.

19

Se il veicolo è dotato di rubinetti elettrici, l'installatore deve fornire e installare il cablaggio per attivare i rubinetti elettrici o la pompa dell'acqua, collegandolo all'apposito connettore situato all'uscita del raffrescatore.

Questo connettore fornisce (-) 12 V (negativo).

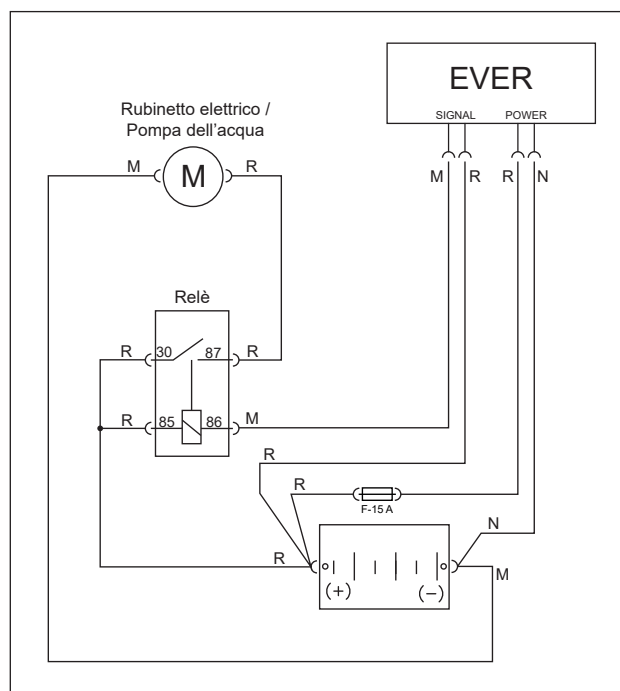

20

Collegare il cablaggio di alimentazione (positivo e negativo) alla batteria. Collegare il cablaggio del segnale al positivo della batteria.

**Nota bene:** per il corretto funzionamento dell'unità, il cablaggio di alimentazione e quello del segnale devono essere collegati direttamente alla batteria.

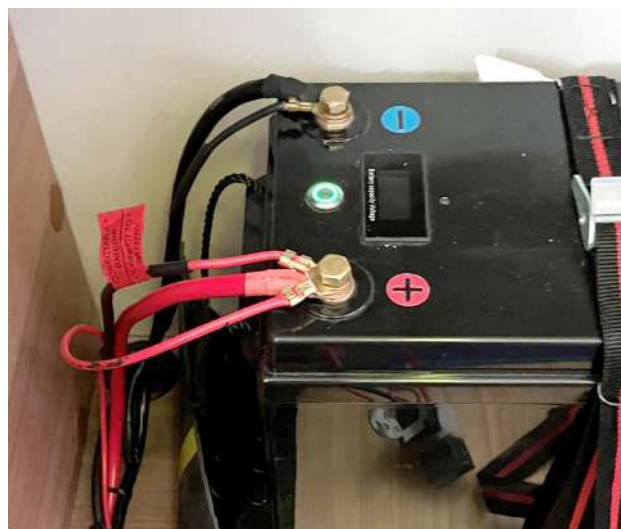

**Nota bene:** prima di mettere in funzione l'unità, consultare il Manuale dell'utente, riferimento: 1003652994 reperibile sul sito [www.bergstromspain.com](http://www.bergstromspain.com) per stabilire la corretta configurazione dell'unità.

**SCHEMA ELETTRICO**

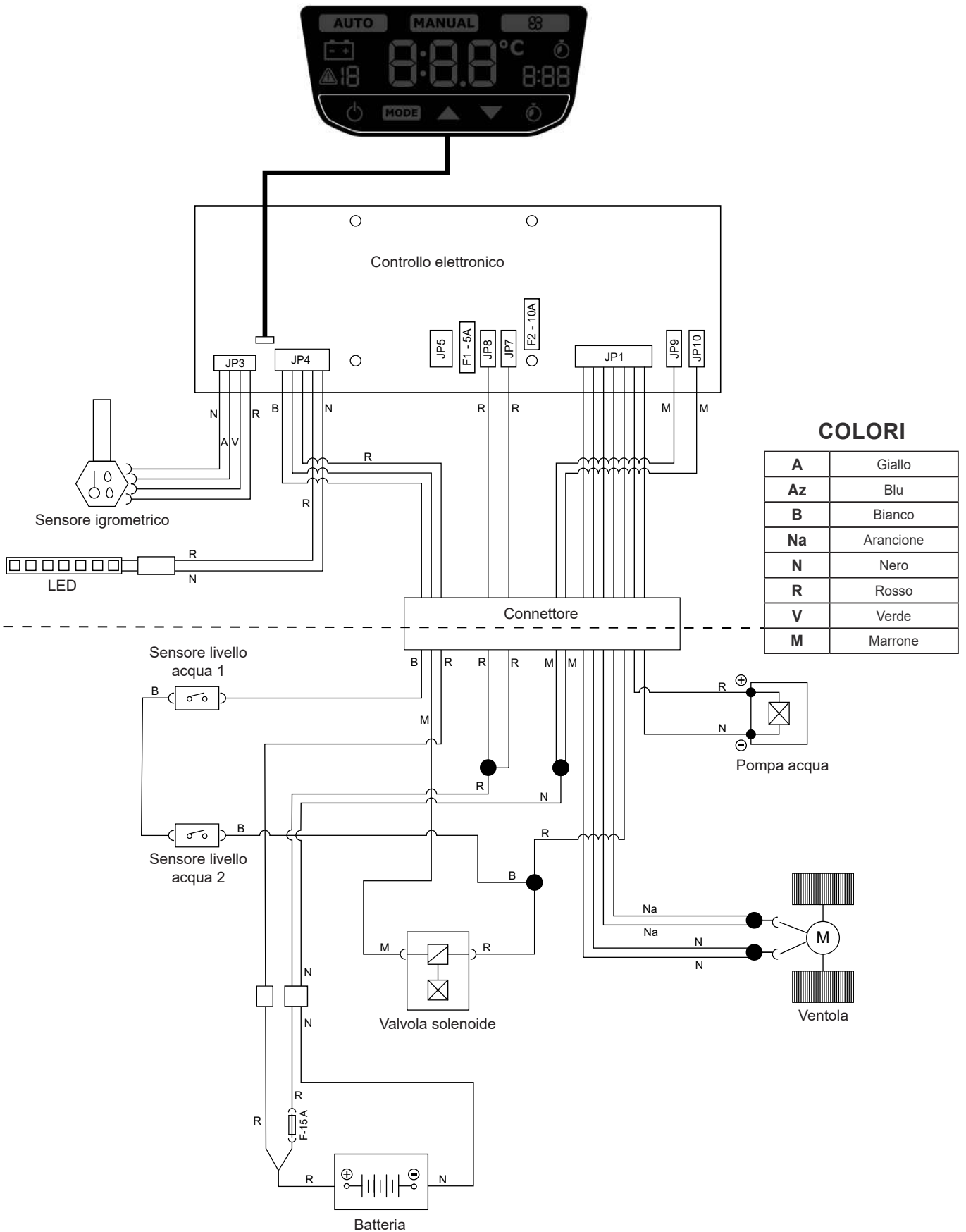







TU ESPACIO DE VIDA CONFORTABLE

**Madrid, España**

T. + 34 - 918-775-840

E. [ventas@dirna.bergstrominc.com](mailto:ventas@dirna.bergstrominc.com)

W. [www.bergstromspain.com](http://www.bergstromspain.com)

